

Spencer® FastVac® Vacuum Cleaning Systems

Serial No:

Model No:

Handling, Installing and Operating Instructions



Stationary Model

Shown with optional HEPA filter.



Mobile Model

Shown with optional HEPA filter, hose and tools.

Important

Read and become familiar with this manual prior to installing your Spencer FastVac equipment. Following the instructions detailed here will help you realize its full potential of efficient service and extended lifespan. Damage resulting from failure to follow correct procedures will void the warranty.

Contents

	Page
I Warranty.....	2
II General Introduction	2
III Handling and Storage	3
IV Installation	3
V Operation and Adjustments.....	5
VI Maintenance	5
VII Vortex Vacuum Producer	6
VIII Troubleshooting Guide.....	7

I. Warranty

We warrant this product will be free from defects in materials and workmanship for a period of 18 months from date of shipment or 12 months from date of start-up, whichever comes first. Within the warranty period, we shall repair or replace, F.O.B. our Factory, such products that are determined by us to be defective.

This warranty will not apply to any product which has been subjected to misuse, negligence, or accident or misapplied or improperly installed. This warranty will not apply to any product which has been disassembled, repaired or otherwise altered by any persons not authorized by our Service Department.

The guarantee of the motor and control manufacturers will govern the extent of our guarantee on such equipment.

Refer to Form 706 for complete terms and conditions of sales.

II. General Introduction

Locate the Spencer nameplate on the FastVac support stand. Record the serial number and other data. Have this information available when contacting your Spencer Representative or the factory, to ensure prompt, accurate service.

Description

The FastVac unit is a powerful, integrated, continuous-duty vacuum system consisting of a Spencer Vortex® regenerative vacuum producer connected to a two-stage cartridge separator with removable dirt can, all mounted on a heavy-duty steel frame. Mobile units also have casters and a handle for easy maneuvering.

Both stationary and mobile units are designed for use with Spencer vacuum hoses and specialized cleaning tools for effective dirt removal from all types of surfaces.

Safety Precautions

Caution: The FastVac unit must not be used for liquid pick-up or for vacuuming volatile, viscous, flammable or explosive materials. If such conditions exist, consult your Spencer Representative for a special-purpose system.

The vacuum producer becomes hot during operation and may cause burns if touched.

Do not operate the motor under load conditions which exceed the rated full-load amps on the nameplate.

Do not install the FastVac unit in any area which may have an explosive atmosphere or which may contain flammable

gases or liquids. Always provide proper ventilation. Do not install in any area which may subject the unit to corrosive liquids.

Before installing explosion-proof motors, check federal, state and local codes to see if such motors are appropriate for the intended application environment. It is the buyer's responsibility to determine the suitability of this product for a particular purpose.

Stationary Model

The stationary FastVac unit is intended for permanent installation in one location, connected to a vacuum tubing system. Since the motor starter is usually installed in a remote location, it is not furnished but is available as an optional Spencer accessory. Contact your Spencer Representative for details.

Vacuum tubing and fitting systems are available from Spencer in carbon steel, zinc coated steel, aluminum and 304 stainless steel. Inlet valves and other system accessories are also available. Contact your Spencer Representative for a catalog of these products.

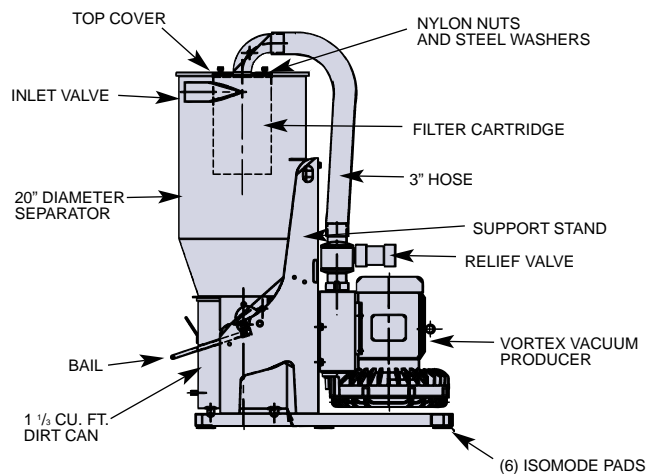

Mobile Model

The mobile FastVac unit is self-contained and easily moved to various points of use. It is equipped with a motor starter, 50' power cord (plug not supplied) and vacuum inlet valve (one or two depending on the model).

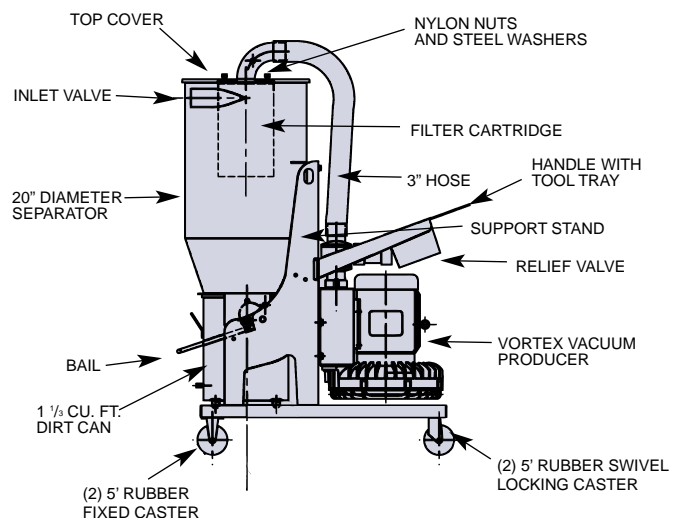

III. Handling and Storage

The FastVac system is shipped on a skid, securely crated, with all openings sealed at the factory. It may be stored in this manner, under cover. Use accepted rigging practices to move the system for storage or installation.

Unpacking

Unpack the machine from the shipping crate and skid. (The stationary model should be unpacked in its permanent location to simplify handling.)

NOTE: Inspect the machine for damage and report any shipping damage to the carrier. If there is any other damage, contact your Spencer Representative.

NOTE: Small parts or accessories may have been shipped in the dirt can. This is a standard shipping procedure to keep orders organized. Lower the dirt can by lifting the bail and remove any loose parts inside.

IV. Installation

Location

This equipment is designed for operation at or near sea level atmospheric pressure and a nominal ambient temperature of 70°F (21°C). The ambient temperature should not exceed 104° F (40° C). The area of use should have adequate ventilation to disperse warm exhaust air from the vacuum producer. Contact your Spencer Representative if your conditions differ.

Stationary Model. Position the machine on a level concrete floor, concrete pad or any other substantial floor, over the four furnished vibration isolation pads. Be sure the machine can be reached for servicing and that the dirt can is accessible for emptying.

Mobile Model. Any flat, dry, level surface is suitable. As a safety precaution, set the caster brakes to prevent accidental movement.

Options and Accessories

Many original equipment options and accessory components are available from Spencer to configure a vacuum cleaning system as desired or to adapt a system for specific applications.

- Metal tubing and fittings
- HEPA disposable, high-efficiency filters
- Motor starters (for stationary models)
- Cleaning hoses, wands, tools and accessories
- Vacuum inlet valves

FastVac Setup

Stationary Model. System installation requires a disconnect, starter, electrical service and a vacuum tubing system. Position the machine in its permanent location for operation. Wire the motor starter or control panel to the Vortex vacuum producer motor.

Electrical Wiring

Motor Data—Typical Values, 60 Hz Operation

	Three-Phase		Single-Phase
Model No.	VB-037	VB-055	VB-037S
Power (hp)	5	7.5	5
Voltage (V)	200-230/460		230
FL Amp (A)	13.2-12/6	19.8-17.2/8.6	20.8
Voltage (V)	575	575	
FL Amp (A)	4.8	7	

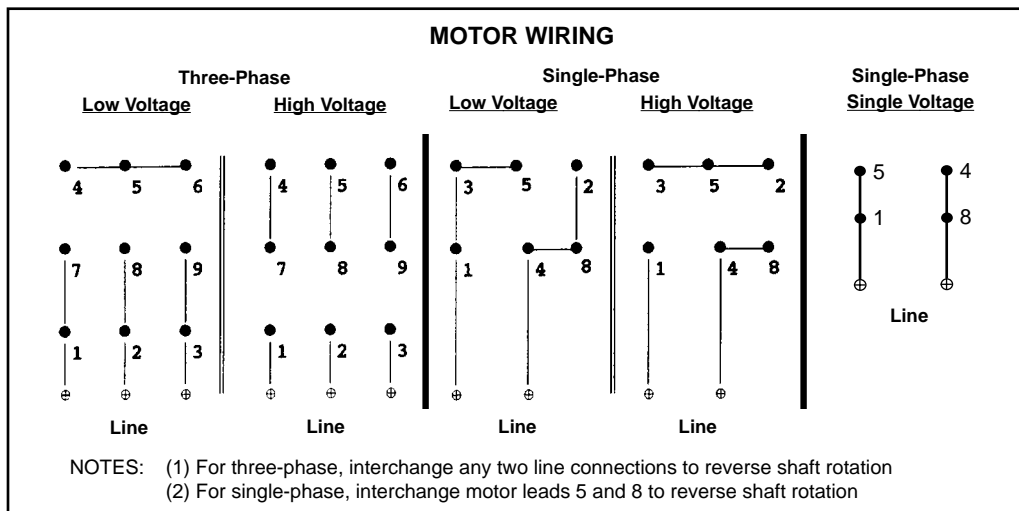

NOTE: All wiring and electrical adjustments or installation should be done by a qualified electrician in accordance with the National Electrical Code and local codes.

Caution: Confirm that the power source is the same as that indicated on the unit's name-plate. Incorrect voltage or improper phase connection may cause motor failure or other damage.

Use conductors and devices such as circuit breakers, starters and switches that comply with the National Electrical Code and applicable local codes.

Install a properly sized overload device and disconnect dedicated only to the Vortex vacuum producer.

Furnish the Vortex vacuum producer and all associated electrical devices with a proper ground in accordance with all local codes and regulations.

System Test Procedure

NOTE: Before running a system test, remove the top cover and check that the filter cartridge is installed. (If needed, see Filter Cartridge Installation on page 5.) Also confirm that the dirt can is securely in place.

NOTE: For stationary models, perform all tests before connecting the machine to the tubing system. For mobile models, make sure there is nothing connected to the vacuum inlet valve.

Motor rotation test. Stand clear of the separator inlet; keep loose items away from the inlet and the vacuum producer. Turn the machine on. If air is coming out of the separator inlet, or if air is being drawn into the outlet diffuser, the direction of motor rotation is incorrect. To reverse the rotation, (a) for a single-phase motor, interchange motor leads 5 and 8, or (b) for a three-phase motor, interchange any two of the three line connections.

Vacuum relief valve test. With the machine running, cover the separator inlet with a board or other solid object, cutting off the incoming airflow. This machine is equipped with a vacuum relief valve which should open, allowing room air into the Vortex vacuum producer and bypassing the separator. This is an important safety provision to protect the vacuum producer from potentially damaging airflow loss. Check to be sure the motor is not running above its full load ampere rating shown in the Motor Data table. If the test is successful, turn the machine off.

Vacuum Relief Valve

Vortex Model No.	Maximum Vacuum H ₂ O	Recommended Vacuum	
		H ₂ O	CFM
VB-037-B	80	79	25
VB-055-B	81	80	100
Vortex Model No.	Adjustable Spring Range H ₂ O	Part Number	Pipe Size
VB-037-B	65-100	VLV90317	2"
VB-055-B	65-100	VLV90317	2"

If the valve does not open, adjust the vacuum relief valve setting. Remove the screen cap, hold the retaining nut or allen head with a 1/2" wrench and turn the stud with a screwdriver. To make accurate adjustments, use an ammeter or vacuum gauge. Do not exceed the full load ampere rating of the motor (see Motor Data table on page 3 or motor nameplate for rating.)

Caution: If the vacuum relief valve does not operate correctly, failure of the Vortex vacuum producer may occur. It must not operate in a low-flow condition.

For stationary models connect the vacuum tubing network to the separator inlet using supplied rubber sleeve and clamps to isolate the machine from stress, vibration and tubing movement.

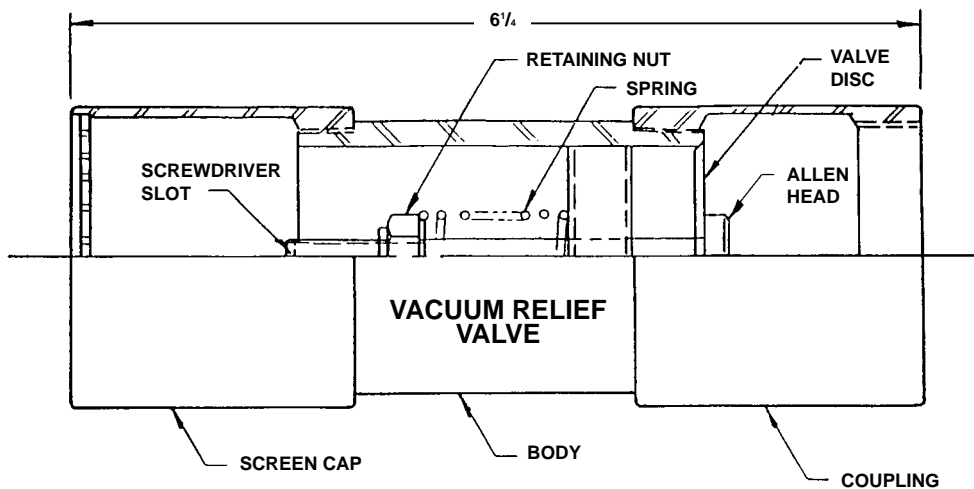

V. Operation and Adjustments

Each FastVac unit is designed to operate as part of a vacuum system that includes a Spencer tubing and fittings network (stationary models) and Spencer hose and tools (all models). These genuine Spencer components are engineered specifically for heavy-duty vacuum cleaning systems; other components may not provide the performance desired.

Machine Startup

1. Turn the FastVac system on, having completed the previous setup procedures.
2. Without any vacuum hoses connected, observe that the vacuum relief valve opens and operates correctly.

NOTE: When no hoses are connected, the mobile FastVac unit and the stationary unit with its attached tubing network are closed systems with no entering air-flow. They must rely on the vacuum relief valve to create a bypass airflow to protect the vacuum producer.

Stationary Model. If the vacuum relief valve is closed and exhaust air can be felt at the Vortex discharge, air is entering the tubing network somewhere. Find the leak and correct it.

3. All Models. With the machine running, connect the Spencer hose(s) and tools. Verify that the vacuum relief valve is now closed.
4. Use the tools to pick up at least a quart of suitable dry dirt or debris.
5. Shut the machine off. Wait for the Vortex vacuum producer to stop. Pull the dirt can bail up and verify that dirt has accumulated in the can.
6. Remove the dirt can and verify that dust has fallen off the filter cartridge into the can. Empty the can.
7. Reposition the can and push the dirt can bail down to lift the can against its gasket. Your system is ready to use.

Limits of Operation

Maximum permissible vacuum is listed on the FastVac nameplate; when it occurs during operation, the minimum allowable airflow (CFM) also occurs. Maintain the operating vacuum at less than maximum to avoid low flow operation and overheating of the vacuum producer. (See vacuum relief valve settings on page 4.)

Caution: Overheating the vacuum producer at low-flow conditions may create a burn hazard. Do not touch the operating machine.

VI. Maintenance

Vortex Vacuum Producer

For maintenance information about the Vortex vacuum source consult Spencer or obtain a copy of the Vortex manual, Form ZZ.

Vacuum Relief Valve

No maintenance is required.

Separator

Empty the dirt can daily when the FastVac system is new. It will likely collect large amounts of material at first. After a while, the daily collection will stabilize at a normal load for your particular facility. At that time, establish the appropriate interval for dirt can emptying.

Cartridge

Clean the filter cartridge daily or more often if suction drops from excessive cake build-up. To reach the cartridge, remove the top cover and place it on the floor with the bottom of the filter resting on the floor. Loosen and remove the four nylon nuts holding the cartridge to the top cover. Lift the top cover off the filter cartridge.

Use a soft paint brush or compressed air to carefully remove any dirt cake on the outside of the cartridge. Or, since a spare cartridge is provided, you can remove the dirty one, install the spare and use the vacuum system and tools to clean the dirty cartridge.

Replace the cartridge when if it can no longer be cleaned, if it gets damaged by materials collected or is torn. Spare cartridges may be purchased from Spencer.

To install a new cartridge, place the bottom of the filter on the floor with the four studs facing up. Lower the top cover over the studs. Install a steel washer and nylon nut on each stud and tighten.

NOTE: If a ground wire is connected to the filter cartridge, it must be reconnected to a ground lug on the cartridge plate assembly.

NOTE: All gaskets must be in place and properly aligned when the cartridge is reinstalled.

CAUTION: Dust coming out of the vacuum producer outlet may indicate a damaged cartridge. Shut off the system immediately and inspect the cartridge as well as the sealing system which holds the cartridge in place.

Housing

The exterior of the machine is painted with a urethane semi-gloss finish over an epoxy primer. Periodically wipe down the machine with a dry cloth or use a non-abrasive water-based cleaner to remove stubborn dirt. Do not spray water onto the machine or electrical connections. An automotive wax may be applied to the machine exterior to help protect the finish.

Vacuum Producer Lubrication

No lubrication is required.

Separator Lubrication

The dirt can bail arm bushings and cam surfaces should be oiled periodically.

Connection Hose

Periodically check the hose that connects the separator and Vortex vacuum producer. Replace it if worn or cracked.

Recommended Spare Part

Standard Filter Cartridge FIL90248

Custom or grounded filter cartridges are available; contact Spencer.

VII. Vortex Vacuum Producer

Acoustical Noise

(Estimated level at 1.5m, 60 Hz)

Model dBA

VB037 76

VB055 82

Parts List

- 1 Case
- 2 Impeller
- 3 Base
- 4 Cover, Impeller
- 5 Locknut
- 6 Lockwasher
- 7 Shim, Shaft to Impeller (As Required)
- 8 Motor
- 9 Hex Head Bolt
- 10 Lockwasher
- 11 Flatwasher
- 12 Hex Head Bolt
- 13 Flatwasher
- 14 Screw
- 15 Lockwasher
- 16 Flatwasher
- 17 Socket Cap Screw
- 18 Case Gasket
- 19 Flange Gasket
- 20 Flange
- 21 Screw
- 23 Plug
- 25 Absorber
- 26 Absorber Screen
- 27 Key
- 28 Lip Seal
- 28A Viton Lip Seal
- 29 Spacer, Washer (Case to Base)
- 30 Impeller To Case Gap Specification
- 31 Case Plate

Assembly Diagram for
Models VB037, VB055

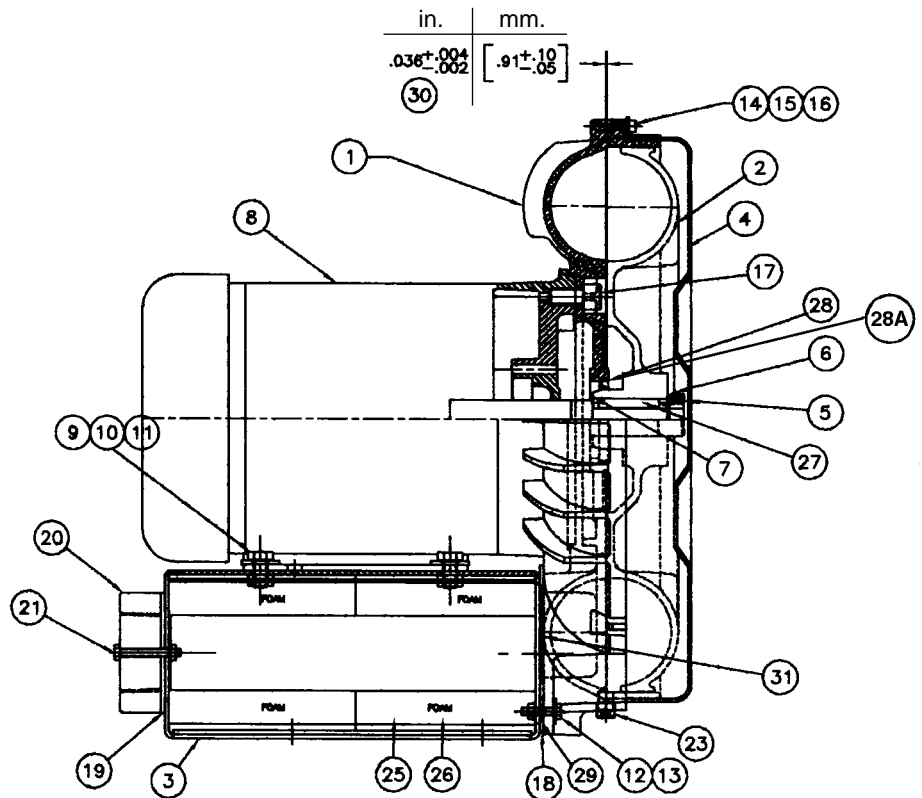

VI. Troubleshooting Guide

PROBLEM	Possible Cause	Corrective Action
MOTOR DOES NOT TURN AND THERE IS...		
HUMMING SOUND	<ul style="list-style-type: none"> – One phase of power line disconnected – One phase of stator line open – Bearing(s) defective – Impeller jammed by foreign material – Impeller jammed against casing or side cover – Rubbing of rotor core and stator core – Capacitor open (single-phase models) 	<ul style="list-style-type: none"> Connect power leads properly Contact Spencer Change defective bearing(s) Clean impeller Adjust gap Contact Spencer Change capacitor
NO SOUND	<ul style="list-style-type: none"> – Two phases of power line disconnected – Two phases of stator winding open – Faulty switch connection – Fuse blown 	<ul style="list-style-type: none"> Connect power leads properly Contact Spencer Change switch Change fuse
MOTOR TURNS, BUT...		
FUSE BLOWS	<ul style="list-style-type: none"> – Fuse capacity insufficient, wiring fault – Short circuit – Terminals shorted – Excessive load 	<ul style="list-style-type: none"> Inspect wiring Repair Improve insulation and check connections Increase airflow
OVERHEATS OR OVERLOAD RELAY ACTIVATES VOLTAGE DROP	<ul style="list-style-type: none"> – Power source unbalance; possible balanced within 5% and voltage – Operating in single-phase condition – Excessive friction due to defective bearings – Impeller contaminated by foreign material – Impeller rubbing against casing or side cover – Operation at less than minimum rated flow – Incorrect vacuum relief 	<ul style="list-style-type: none"> Check voltage; phases must be must be within 10% of rated Check connections Replace bearings Clean impeller Adjust gap Increase airflow (check relief valve) Adjust bleed
MAKES ABNORMAL SOUND	<ul style="list-style-type: none"> – Impeller rubbing against casing or side cover – Impeller rubbed by foreign material – Bearing(s) defective – There is a leak or air passages are clogged – Loose cap screw 	<ul style="list-style-type: none"> Adjust gap Clean impeller Replace bearings Repair or clean Tighten screw
LOW SYSTEM VACUUM	<ul style="list-style-type: none"> – Clogged filter – Leak in tubing system – Leak in dirt can – Too many operators on line 	<ul style="list-style-type: none"> Clean filter Locate and remove leak Clean or replace gasket Reduce the number of users
DIRT COMING OUT OF EXHAUST	<ul style="list-style-type: none"> – Filter is damaged or improperly installed – Material vacuumed is extremely fine 	<ul style="list-style-type: none"> Replace or reinstall filter Consult Spencer
SYSTEM MAKES HIGH-PITCHED SQUEAL	<ul style="list-style-type: none"> – Leak at a machine joint 	<ul style="list-style-type: none"> Check dirt can and top cover



Products & Services

Industrially rated products offering effective solutions for air and gas moving problems:

- Modular central vacuum systems
- Mobile or stationary integrated vacuum units
- Dust collectors and separators
- Multi-stage centrifugal blowers
- Single stage centrifugal blowers
- Regenerative blowers
- Positive displacement blowers and packages
- Gas boosters
- Custom-engineered products with special materials for extreme temperatures and pressure

Complementary accessories with single source convenience and compatibility:

- Standard and custom electrical control panels - UL, CUL and C.E. Listed available
- Comprehensive selection of tubing, fittings, vacuum hoses, valves and tools
- Valves, gauges, couplings, shrink sleeves, vibration isolators and other system components

Comprehensive engineering and other customer support services:

- The industry's largest complement of technical specialists in air and gas moving technology
- Worldwide parts and service organization
- Application research and testing facility
- Product selection process aided by internal computer program

Worldwide organization of sales representatives and distributors offering:

- Product selection, installation and operation assistance
- Comprehensive system design services
- Follow-up services and troubleshooting

***For the name and telephone number of your local
Spencer Representative, call 1-800-232-4321
or email marketing@spencer-air.com.***



Since 1892 moving air and gas for a cleaner environment

TEL 800-232-4321 ♦ 860-688-8361 ♦ FAX 860-688-0098 ♦ www.spencerturbine.com