

INSTRUCTIONS

HANDLING INSTALLING AND ADJUSTING

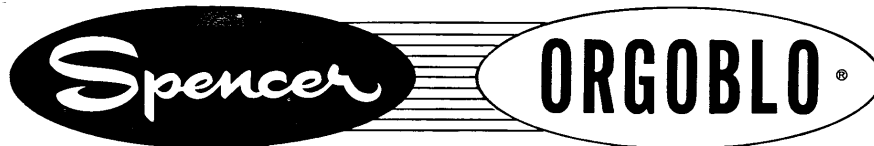

The ORGOBLO, as any other well constructed machine, requires careful and intelligent attention. Therefore, we have prepared this instruction book so that our customers and the users of our equipment may be able to give the ORGOBLO the care it requires. We hope you find this booklet informative and helpful, and we earnestly request that you conscientiously follow the instructions contained within its pages.

INDEX

	Page		
General	2	7. Ball Bearings	
Service		8. Connection to Organ	
Guarantee		9. Controlling Valve	
A. Installation of the ORGOBLO.	2-6	10. Sound Proof Enclosures	
1. Handling		11. Special Notes	
2. Location		B. Care of the ORGOBLO	
3. Foundation		Lubrication	
4. Piping		C. Assembly of the ORGOBLO.	7-8
5. Electrical		1. To Disassemble	
6. Starters		2. To Reassemble	



The **SPENCER** TURBINE CO.

486 NEW PARK AVENUE • HARTFORD, CONN.

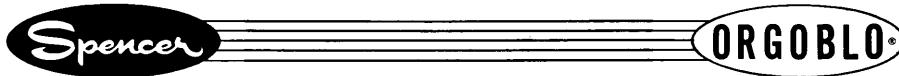

GENERAL

SPENCER SERVICE

Spencer service begins immediately upon receipt of your request for an Orgoblo purchase. Our Engineers welcome the opportunity to discuss your installation problems and will assist in determining specific requirements, if so desired. Spencer service also includes the capability to fulfill your needs promptly. We maintain a large inventory of electric motors and machine parts for the various types of Orgoblo. Also, since the complete unit is constructed in one location, the purchaser is assured of prompt attention and delivery.

All Spencer Orgoblos are tested at the factory—not only for load, but for noise, vibration and for assurance of satisfactory service over many years. Spencer service on repairs is a factor that a purchaser can depend upon for the life of the organ blower. Spencer Orgoblos are built to last; every item in the design and manufacture is chosen on the basis of maximum life of the machine under every condition.

GUARANTEE

All Spencer Orgoblos are guaranteed against defective material or workmanship for a period of one year from date of shipment. Defective parts will be repaired or replaced at our option without charge when failure occurs within this period. This guarantee applies to the equipment when properly used, and does not include any consequential damage or expense involved in changes or repairs by others unless authorized by the Spencer Turbine Company.

The guarantee of the motor and control manufacturers will govern the extent of our guarantee on such equipment.

INSTRUCTIONS FOR HANDLING THE SPENCER ORGOBLO

A. INSTALLATION OF THE ORGOBLO

1. HANDLING

Instruct workmen to handle the Orgoblo with care while putting it into place. Never lift the machine by the shaft end or bearing housing. If the machine is to be stored in a building before being permanently installed, it must be carefully protected from dampness and dirt.

2. LOCATION

Install the machine in a cool dry place, free from dirt and dust. Be sure that the blower is located so that it is easily accessible. You should allow several feet of space around the machine for servicing, should it become necessary. Inaccessibility can prove costly in both time and labor. In selecting the best location for an Orgoblo, several things should be taken into consideration: the size, wind pressure, speed, kind of motor, construction of the building, all have a definite bearing on a satisfactory installation and should be given careful attention. In general, high speed machines should be placed farther away from the organ than slow speed machines so that any humming or other noise peculiar to high speed motors will not be audible in the organ proper. The standard Orgoblo of

small and medium sizes can usually be placed in the basement beneath the organ, or sometimes placed in back of it, if installed in a sound-proof enclosure. Special slow speed machines can be furnished for placement inside the organ or in almost any location desired. This practice, however, is not to be recommended, and, if at all possible, we recommend that the blower be installed in a location somewhat removed from the organ. Particularly large Orgoblos, handling large volumes of wind at various pressures, should be placed at a considerable distance from the organ in a room especially built for them. Large volumes of air, particularly at high pressures, cannot be handled with absolute silence and in order to have a noiseless installation, care should be exercised in providing a suitable location for the blower. The room should be large enough to permit easy access to the motor and blower and also should be well ventilated; otherwise, any heat which is generated will be drawn into the blower and delivered to the organ.

3. FOUNDATION

No elaborate foundation is required for the Orgoblo although a cement base is recommended. Regardless of material, however, the foundation should be of substantial strength and as level as possible. Important: Place the Orgoblo on the felt pads which are furnished with it and under no condition bolt it to the floor in any way.

4. PIPING

All piping should be of ample size to minimize frictional loss. It is absolutely essential that all joints be air tight and that there be no leaks anywhere in the system. Leaking air pipes consume a surprising amount of power and impair the operating efficiency of the Orgoblo. Piping should be properly supported so that no stress or strain is placed on the machine casing.

It is further recommended that the rubber or insulating sleeves supplied with the machine be used to connect it to the piping system.

The table below shows the pipe sizes recommended for the average installation. These pipe sizes have been calculated for various volumes of air and permit a loss of not over 1/2" water column.

C.F.M.	SIZE OF PIPE	C.F.M.	SIZE OF PIPE	C.F.M.	SIZE OF PIPE
200	6 in.	1100	12 in.	3900	20 in.
400	8 in.	1900	15 in.	4800	22 in.
700	10 in.	3000	18 in.	6000	24 in.

If pipe runs exceed 60 ft. in length, use the next size larger pipe given in this table.

Install the flexible canvas wind conductor, supplied with the machine, at or near the blower outlet so as to completely eliminate metal to metal contact between the blower and wind conductor.

5. ELECTRICAL

Be certain that the motor furnished with the Orgoblo is wound for the same type of current available at the installation. In making the electrical connections, following the wiring instructions furnished, it is of the utmost importance that the direction of rotation of the blower is the same as that indicated by the arrow plate. Wire and fuses should be of ample capacity to insure that the proper voltage is maintained at the motor terminals while starting and running the Orgoblo. All wiring should conform to National Electrical Code specifications.

6. STARTERS

The wrong type or the wrong use of motor starters is a major cause of trouble and expense. This can and should be avoided by observing the following suggestions:

- (a) All AC machines should be equipped with a magnetic contactor or a compensator depending upon the machine size and the installation regulations of the local power company.
- (b) The starters should have thermal overload protection as well as true low voltage protection.

7. BALL BEARINGS

The ball bearings in this machine have been designed specifically for the function that they must perform. Impeller loads, both radial and thrust, are carried by one of the bearings and an operating temperature as high as 200°F is no cause for concern. Again, it is essential that replacement bearings be the same type as the original bearings. In most Orgoblos, the front (opposite shaft extension) motor bearing has been designed to take thrust.

8. ORGOBLO CONNECTION TO THE ORGAN

Practically all new organs are provided by the builder with air tube connection to the blower. In attaching Orgoblos to old organs, care should be taken to carefully select the proper place to make this connection. If the "well" of the bellows is high enough, the connection may be made with a round elbow and flange collar, as shown in figure 1. If the "well" is too low to permit use of the round elbow, a wooden box made sufficiently wide to afford an opening in the bellows of at least two-thirds the area of the pipe is a convenient form of connection (See Figure 1).

9. CONTROLLING VALVE

The controlling wind valve which is furnished with the blower should be placed directly at the blower outlet whenever possible. This valve may best be operated mechanically by means of pulley system connected to the organ reservoir (See Figure 1).

If some other type of control valve is used in place of our standard balanced valve, care should be taken to see that it is of ample size so as not to retard the air flow. The frictional loss through any valve increases as the square of the volume of air which is being used; hence, the loss is greatest when the greatest volume is being drawn. A valve of the cone or poppet type needs to be much larger than a standard butterfly type, in order to allow the same volume of air to pass.

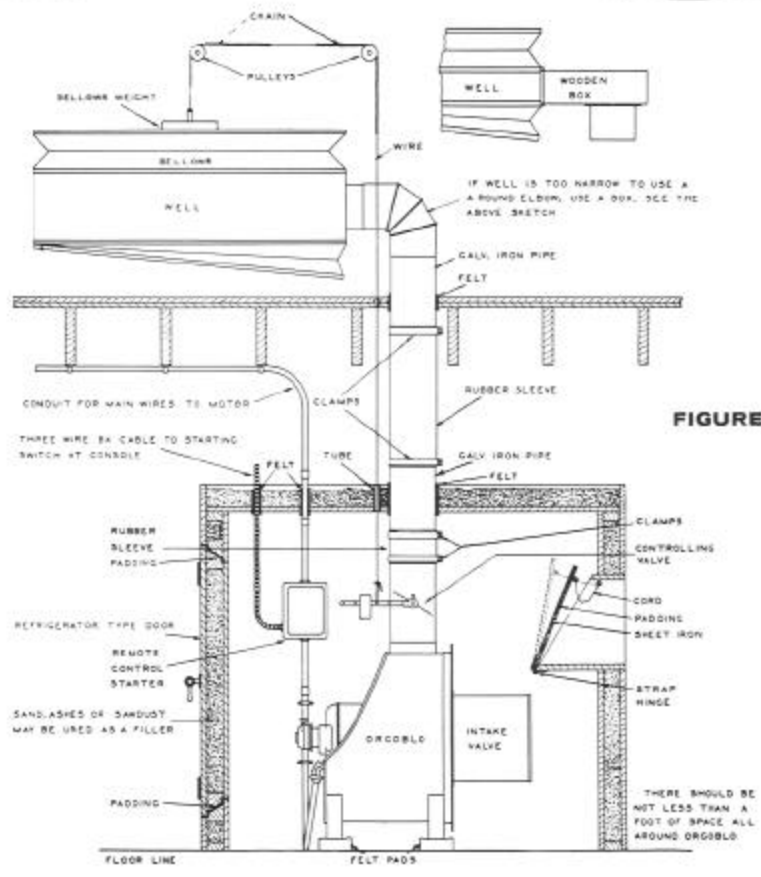

FIGURE 1

10. SOUND-PROOF ENCLOSURES—

Sometimes due to the size and speed of the Orgoblo, high wind pressure, or acoustic properties of the building, it is necessary to sound-proof a blower in order to secure sufficiently quiet operation. Should this be necessary, we refer you to Figure 1, which shows a housing made of double walls, filled with hair felt, sawdust, cork, or some other sound insulating material. This room is constructed similar to a refrigerator and proves very effective.

Another method of sound-proofing a blower is to build a sound insulating box, as shown in Figure 2. These boxes may be lined with any soft-faced sound-absorbing material of which there are many commercially available. Celotex is probably the best known and most readily obtained of any of these materials. All of them, however, prove very effective as sound deadeners and have been used in a great many locations with success.

In building a blower enclosure, be sure to allow for an air intake of ample size similar to those shown in Figures 1 & 2. An air intake of this type permits the air to enter the blower easily and at the same time remains closed or nearly so when the blower is running and using only a slight amount of air.

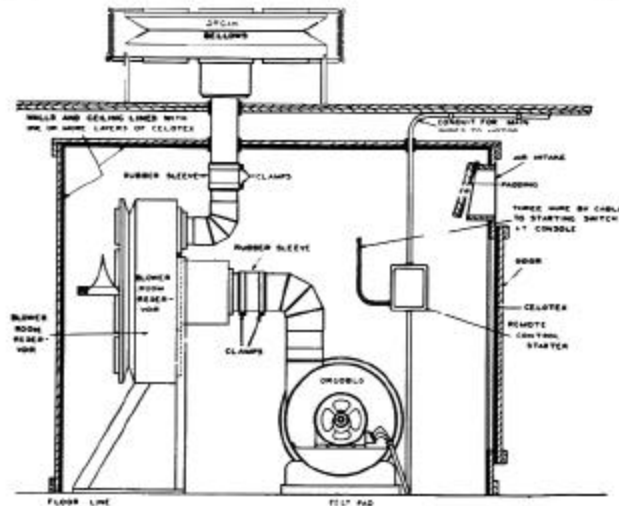

FIGURE 2

11. SPECIAL NOTES—

If there is an occasion to start the Orgoblo before the wind connection to the organ has been completed, be sure to cover or block out the intake of the machine; otherwise, you will overload the motor and possibly injure it.

Do not under any condition try to hang the Orgoblo from the ceiling or rafters overhead.

Felt padding must be placed between all pipes and pipe hangers or supports. Failure to do this will result in a noisy installation.

B. CARE OF THE ORGOBLO

It is assumed:

- That the Orgoblo will be installed in a level place on the felt pads furnished.
- That it has received reasonable care in handling.
- That all instruction tags, plates and sheets have been read and followed.
- That the place where it is installed is reasonably dry and clean.
- That the blower is connected to the wind pipe with the flexible rubber sleeve furnished with the machine.
- That all piping is absolutely air tight and of ample size.
- That the solid electrical conduit is not attached in any way to the motor or blower casing.

1. LUBRICATION—

It is most important in the care of the Orgoblo to see that the lubricating instructions are conscientiously carried out, as no machine will give permanent satisfaction without adequate and sufficient lubrication.

Do not assume that "any kind" of lubricant will do. If good service is expected, high grade lubricant free from acid, grit, or dirt must be used. For ball bearings in the blower, we recommend lubrication every 1500 running hours. The actual length of service before re-lubricating depends on the size and speed of the motor, type of service, environment, and related factors. Where grease cups or fittings are provided, re-lubrication should be done in accordance with the following instructions and while the unit is running at full operating speed:

- (a) Remove drain plug.
- (b) Wipe grease cup or fitting clean (as well as the area surrounding it) and inject grease only until new grease appears at the drain plug opening.
- (c) IMPORTANT: Allow the unit to run with the drain plug open long enough to expel all excess grease.
- (d) Replace drain plugs.

It is desirable every 2 or 3 years to wash all the grease from the bearings for thorough cleaning. Proceed as follows:

- (a) Keep unit at full operating speed and remove grease cup.
- (b) Inject a suitable solvent until the housing is full.
- (c) Run the unit for a short interval and remove drain plug.
- (d) Repeat the procedure until clean solvent drains out.
- (e) Follow cleaning with a bath of light lubricating oil in order to remove all traces of the solvent.
- (f) Grease in accordance with the above instructions.

Only high grade grease having a consistence slightly greater than petroleum jelly and a melting point above 275°F should be used for bearing lubrication. It is recommended that Lubriko, M-6 be obtained if more grease than that supplied is desired. The Spencer Turbine Company will ship a supply promptly upon receipt of your order.

The absence of grease cups or other lubricant fittings indicate that the motors are equipped with pre-lubricated, sealed bearings which require no attention.

If sleeve bearings are used, keep the oil wells filled with tycol #303 lubricating oil available from the Spencer Turbine Company.

C. ASSEMBLY OF THE ORGOBLO

1. TO DISASSEMBLE—

IMPORTANT—Parts must be reassembled in exactly the same relative positions. Therefore, it is recommended that each part be marked as it is removed from the machine to facilitate later reassembly. It is especially important that the location of each impeller as well as its position on the shaft be marked.

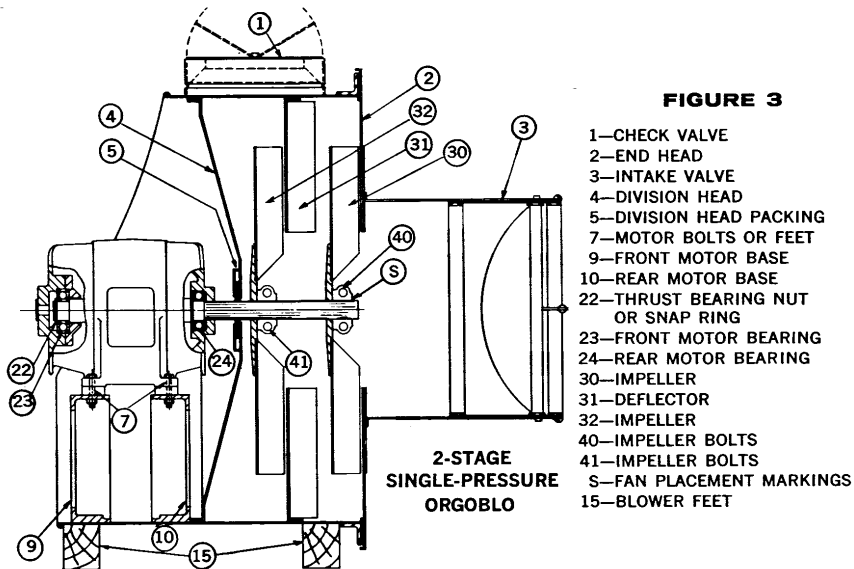

To disassemble the Orgoblo (Refer to Figures 3 or 4) begin at the intake end and remove the intake valve #3, end head #2, impeller #30, deflector #31, impeller #32, etc., and so on until all impellers and deflector heads have been removed. To dismount the motor, remove the bolts from the feet #7 and slide the motor straight back, being careful not to injure the packing #5 around the shaft.

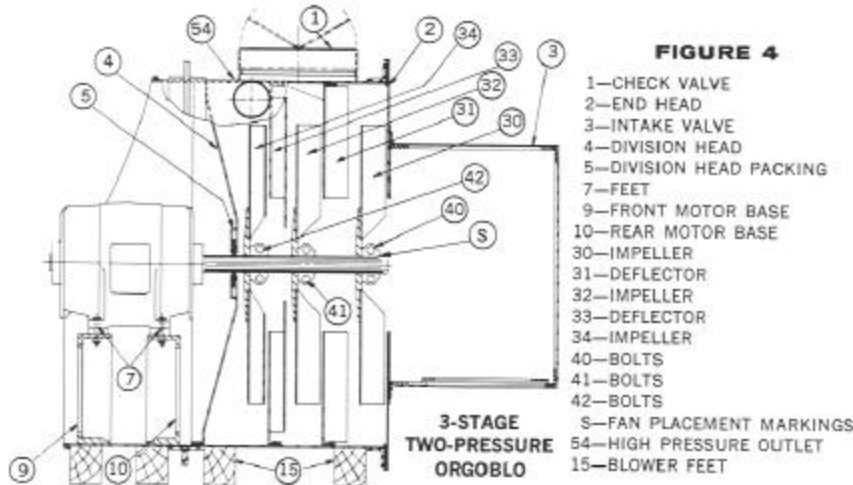

2. TO REASSEMBLE—

Bolt the motor down tightly into its original position. Make sure that the shaft is in the exact center of the blower casing and parallel to it. See that the packing #5 is in place and fits tightly around the motor shaft. If this has been deranged in the moving of the motor or otherwise, a new packing should be installed before the motor is replaced.

Before assembling the fans, start the motor and make sure that the shaft runs absolutely straight and true.

Proceed with assembly as follows:

- a. Place impeller #34 on the shaft but do not tighten it.
- b. Next, insert deflector head #33 and be sure that it is driven back tightly against the stops. These deflector heads may be most easily put in place by sliding them into the casing at the bottom first and then driving them at the top until they come up tightly against the stops.
- c. Set the first impeller so that the edge of the blade runs approximately $\frac{1}{2}$ " away from the deflector head in front of it. In setting this impeller, be sure that your reference marks coincide exactly.
- d. Tighten the fan hub bolts so that there will be no possibility of the impeller slipping on the shaft.
- e. Place the second impeller #32 on the shaft without tightening and proceed in a like manner with the rest of the deflector heads, impellers, and the end head.

WHEN QUALITY and SERVICE ARE REQUIRED ... SPECIFY SPENCER



THE SPENCER TURBINE COMPANY
HARTFORD, CONNECTICUT