

SPENCER
HARTFORD

ORGOBLO
J U N I O R

FOR SMALL PIPE ORGANS
and
REED ORGANS OF ALL SIZES

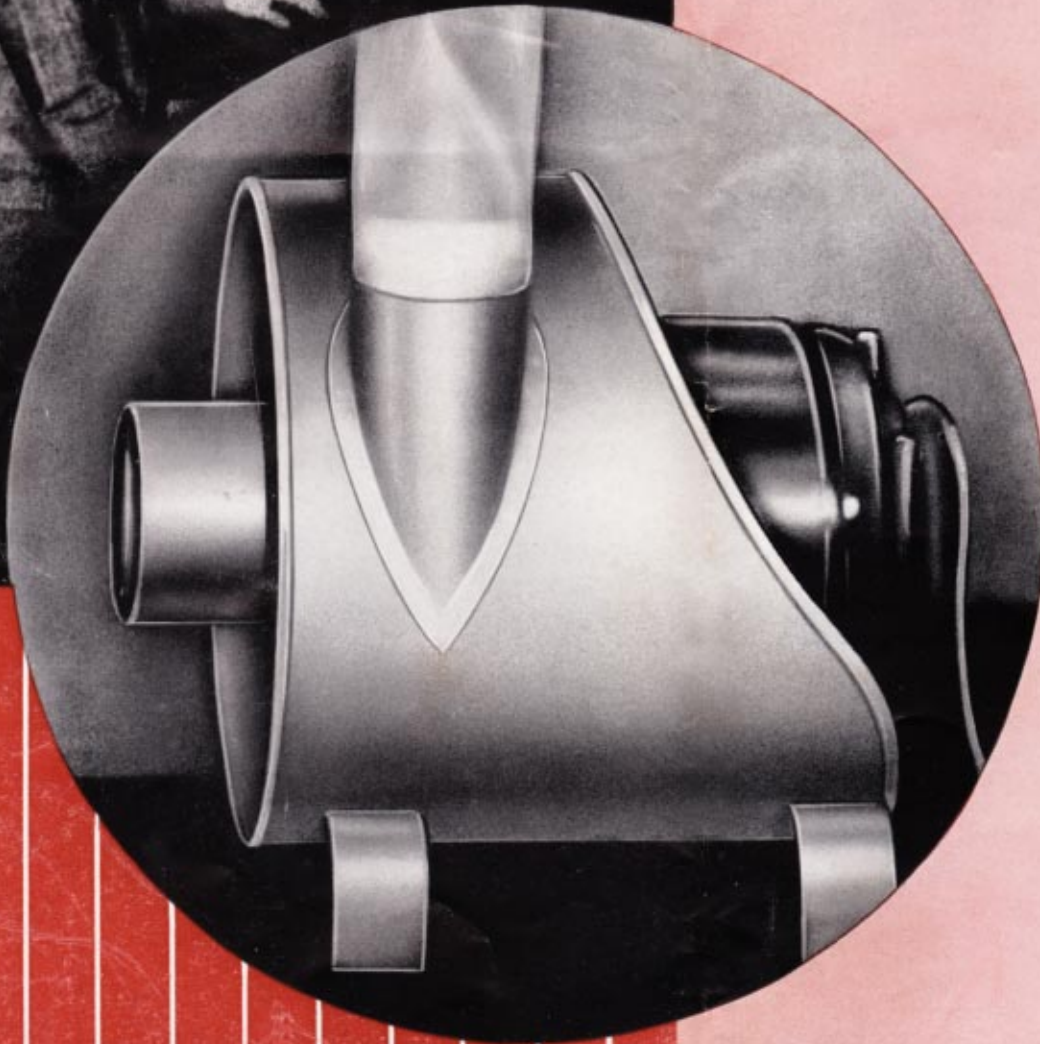

BULLETIN NO. 106



The Spencer Orgoblo Junior

THE FIRST Spencer Orgoblo, placed in service more than thirty years ago, was built primarily to eliminate hand pumping. It soon became evident that the Orgoblo was destined to enable the manufacturers to design and produce organs of more accurate performance, with finer control and, as time went on, much larger in size and better in quality of tone than had ever been contemplated before the introduction of the Orgoblo. Today the great majority of all church, auditorium and residence organs are operated by Orgoblos, many of which have given highly satisfactory service for more than a quarter of a century and are still in operation.

In recent years, organ builders have been applying wind power to even the smallest pipe organs and to reed organs of practically all sizes. These applications called for a unit that would be small, light in weight, and practically noiseless. The Orgoblo Junior, developed fifteen years ago to meet these conditions, has been steadily improved and reduced in size from year to year.

Its qualifications are typified in the installation on a portable organ shown on the cover of this book.

The space occupied by the Orgoblo, located within the organ, is unusually small. The operation is so quiet that even radio technicians failed to detect any objectionable noise during the many broadcasts that have been made with the Orgoblo operating inside the organ and only a few feet from the microphone.

The Orgoblo Junior is in no sense a cheaper model of the larger Orgoblos. Made of the same materials, designed by the same engineers using the same principles as on the larger models, the Orgoblo Junior is just as sturdy, and just as efficient, and has the same life-time service characteristics, as the larger units.

As you will see from the following pages, it is a machine of exceeding simplicity; and yet it is so carefully designed and constructed, that a smooth, steady and inexhaustible wind supply is maintained at all times, thereby enabling any instrument to which it is attached, to operate with its full power and efficiency. It is an ideal of simplicity, effectiveness and durability.

The Orgoblo Junior is now furnished in five sizes, namely: 1/8, 1/6, 1/4, 1/3, and 1/2 Horse Power.



*Side View of 1/6 Horse Power
Orgoblo Junior with Muffler*



Motor End—1/6 Horse Power Orgoblo Junior



The Spencer Orgoblo Junior is manufactured in two types: first, the STANDARD ORGOBLO JUNIOR, which is designed and built for ordinary applications. This blower is intended where it is possible to be installed in the basement or adjoining room and is connected in the customary manner by means of a wind conductor to the reservoir of the organ.

The second type, the FELT-LINED ORGOBLO JUNIOR, is a machine, designed for quiet operation and is primarily offered to meet the demand for a small, compact blower, which may be installed directly within the case of portable instruments. These blowers are given very careful attention to insure exceptional quietness, have capacitor type motors, designed and built to Spencer specifications and the blower casings are completely lined with felt in order to minimize the windage noise as completely as possible.

For any given horsepower, the ratings are the same for either the standard or the specially quiet Orgoblo Juniors and it should be stressed that the regular machine is sufficiently silent in operation for the average install-

ation where the blower is installed apart from the instrument. However, if it is desired to mount the blower directly within the organ case, the specially quiet model should be used.

Space here does not permit complete recommendations as to the correct size of blower for all types of instruments. Since the Orgoblo Junior is manufactured in sizes ranging from $\frac{1}{8}$ to $\frac{1}{2}$ H. P., there is a unit available for anything from the smallest single manual reed organ to the largest two manual and pedal instrument. As for pipe organs, this range of sizes will take care of the majority of the portable and the semi-portable instruments now on the market. Naturally, the number of sets of pipes and the wind pressure on which the pipes are voiced will determine the actual blower requirements for a given instrument.

If you have any specific problems we would suggest that you communicate with the Organ Power Division at Hartford, who will be glad to make recommendations for any application, which may be encountered.

Fixtures

The Orgoblo Junior may be readily adapted for either suction or pressure, and, therefore, has the decided advantage that it is suitable for a large range of requirements.

The following cuts indicate very clearly the methods of connecting the Orgoblo Junior to an organ. Cut No. 3156, page 4, shows the usual method of attaching the machine to a Reed Organ where suction is required, and No. 3391, page 6, shows a typical installation on a pipe organ where pressure is required.

For Suction

The following fixtures are included with each Orgoblo Junior Outfit when used for suction:

$3\frac{3}{4}$ in. I. D. 10° flanged collar and valve seat; valve disc, with support, spring and cotter pin; 4 in. rubber sleeve 4 ft. long; six 4 in. clamp collars to fit hose; 4 in. rubber sleeve $5\frac{1}{2}$ in. long; 5 ft. of 4 in. g. i. pipe; 1 ell, 1 strip of gray felt 18 in. long, hair felt for placing under blower, lubricant and booklet.

For Pressure

The following fixtures are included with each Orgoblo Junior Outfit when used for Pressure:

$4\frac{1}{2}$ ft. flexible rubber wind tubing, 2 clamp collars, 1 flanged collar, hair felt for placing under the blower, motor lubricant; balanced controlling wind valve complete with lever, pulleys, chain, etc.

If extra pipe or fittings are required they can be supplied at small additional cost



Instructions

For Connecting "Orgoblo Junior" to Reed Organs with Vertical Bellows

Location

PLACE blower on a dry basement floor or other suitable location as near under the organ as convenient (see Cut No. 3156) and be sure it touches absolutely nothing but the felt on which it stands and the 4 in. rubber air tube connections. Also be sure that the machine stands level.

Do not under any condition try to hang the Orgoblo Junior from the ceiling or floor above.

Piping

If the metal pipe between blower and end of rubber air tube is not over 40 ft. long, use 4 in. diameter conductor. If over 40 ft. long, use 5 in. up to the end of 4 in. flexible hose.

Felt must be placed between all pipe and pipe hangers or supports. (Failure to do this will cause a noisy outfit.)

Connection to Organ

At a small extra cost new organs can be equipped in the factory with the controlling valve installed ready to slip on the short rubber end of the 4 in. hose and secure with metal clamp. (Place clamping screw at bottom.)

After a suitable location has been selected for the organ, cut a 5 in. round hole through the floor $\frac{1}{2}$ in. from the back wall. Line this hole with felt, and slip the 4 in. flexible rubber hose down through it.

When moving the organ back towards the wall, be sure that the hole in the floor rests opposite the hose connection to organ and that the organ is not less than 7 in. or more than 9 in. from the back of the 4 in. rubber hose.

Next connect the lower end of the 4 in. hose or pipe line to the intake of the blower (see Cut No. 3378, page 5). The equipment is then ready to use.

Electrical Connection

Be sure the *metal* conduit, (if such be used to carry electric wires) is not attached to the blower or motor but is stopped a foot or so from either, allowing the wires only or a piece of *flexible* conduit to be attached to the motor.

Be sure to read carefully wiring and lubricating instructions attached to machine before wiring it up or starting.

It is essential that the voltage marked on the motor name plate should be maintained *at the terminals of the motor*. If this is not done, a burned out starting coil may result.

While it is sometimes possible to maintain the proper voltage with a lamp socket connection, there is danger of cutting down this voltage if connection is made to fully loaded lighting lines. *We, therefore, strongly recommend running separate wires from the meter board and*

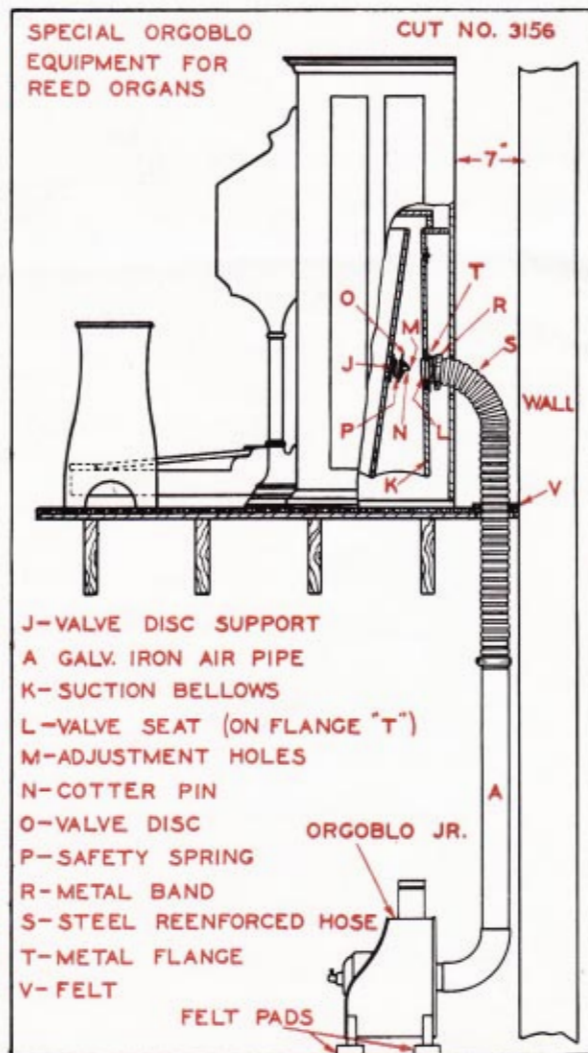



connecting a little pilot light at the starting switch to remind the organist to shut off the machine when through.

The voltage at the motor terminals can be tested with an ordinary test lamp, which should remain constantly bright whether playing the organ heavy or light.

Enclosing

If necessary to box the blower (see page 7), an opening must be made in the box to permit the escape of the air from the blower and in any case provision must be made for easy access to inspect, clean and lubricate motor, per lubricating instructions attached to machine.

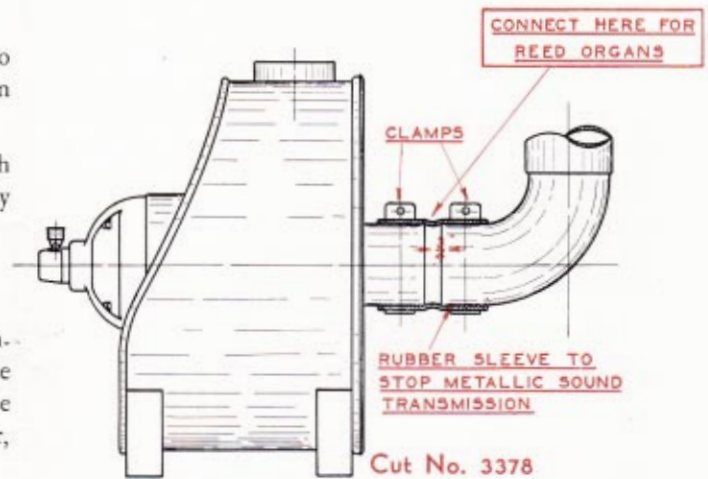

To Install

Controlling Valve Disc and Hose Connection to Reed Organs Already in Use

DRAWING "A", Cut No. 3385, shows the reservoir with a 4½ in. round hole, the center of which should be 14 in. from the bottom of reservoir.

To locate the proper position for the valve disc support "J", close the reservoir up so that the movable part is parallel with the stationary part as shown in drawing "B," then insert a pencil through the 4 in. hole, marking a circle on the back "I" as shown.

Next place the valve support as shown in drawing "C" so that the round flange "J" will rest in the center of the circle marked with lead pencil and secure it firmly with three screws. Next insert the valve disc "K" through the 4½ in. hole as shown in drawing "E" and insert the cotter pin in one of the holes as at "L", being sure to spread the ends of the cotter pin. (The holes nearest the back give the highest pressure in the reservoir.) Next screw on the flange "M" as shown in drawing "F," being sure that the 10 degree angle aims in a downward direction. Next close the reservoir as shown in drawing "G" to make sure that the support stem "N" is substantially in the center of the inside end of the flange; next connect the 4 in. rubber hose onto the flange as

shown in drawing "H," screwing up firmly the clamp collar "O," being sure that the clamp screw is at the bottom. If air sucks in at safety valve when not playing, the pressure in reservoir is too high—remove flange "M" and put cotter pin in a hole nearer the opening.

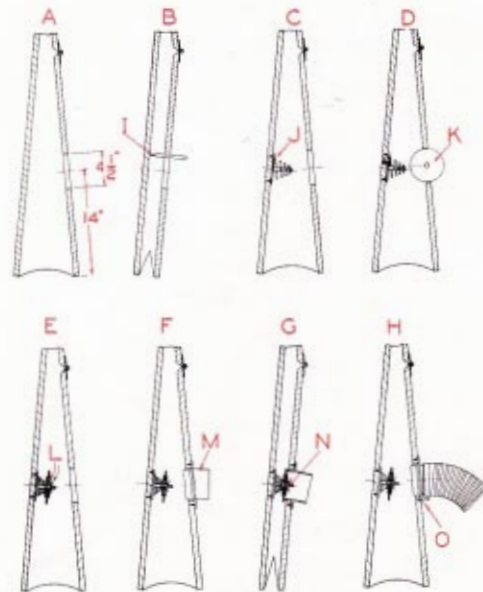

Cut No. 3385

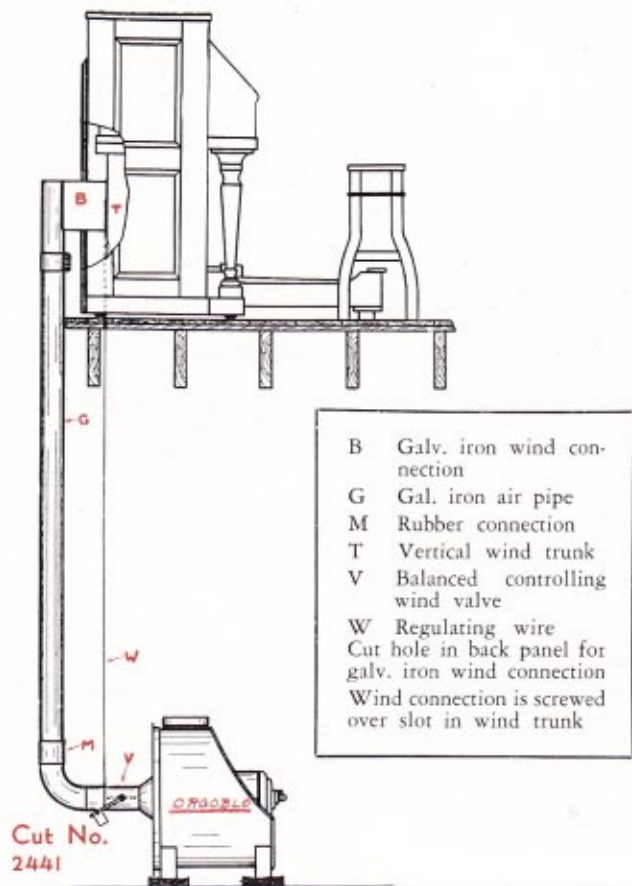

Reed Organs With Horizontal Bellows

The preceding instructions are applicable for reed organs which are equipped with vertical bellows, such as the Estey and others. For reed organs having horizontal bellows, such as the Mason & Hamlin Lizzt Organ, the method of connection is somewhat different. For a proper installation on a reed organ of this kind we would refer you to Cut No. 2441.

Most organs of this style are or may be provided with a slot about 8 in. x 1 1/4 in. in the vertical wind trunk at the back of the base end of the organ. It is intended that the blower connection should be made at this point.

When it is specified in ordering that the Orgoblo Junior is to be used with an organ of this type, an Orgoblo "Connection Box" is provided so that the wind conductor may be readily connected to the organ. This connection box greatly facilitates the installation of the machine, and has proven entirely satisfactory in a great many instances.

Otherwise the installation of a blower on this organ is similar to that described for a reed organ with vertical bellows. On this type of installation the flow of air is controlled by the valve "V", which is regulated by a chain and pulleys from the reservoir in the bottom of the organ. This valve should be completely closed when the organ reservoir is deflated, or nearly so. If the valve is thus adjusted, the operation of the organ will be thoroughly satisfactory.

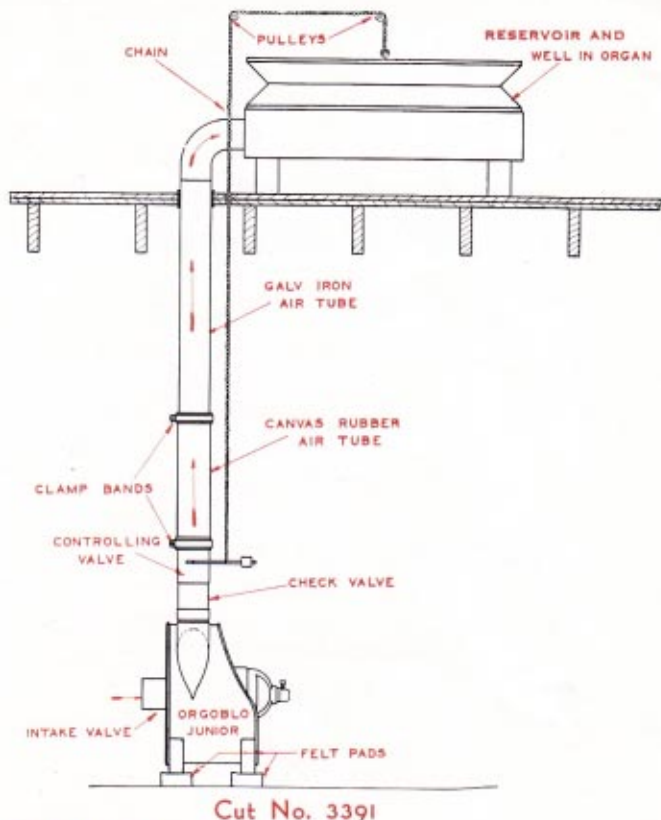

Instructions

For Installing Orgoblo Junior to Small Pipe Organs

If the Orgoblo Junior is to be used with a pipe organ connection is made in identically the same manner as the larger Orgoblos are installed. Usually the organ is provided with some sort of a blower connection on the main reservoir or bellows.

In case the machine is to be used with an organ which is quite old, it may be necessary to make this connection yourself. If this is true, the easiest method is to connect to the main bellows by means of a flanged collar and galvanized iron elbow. The flanged collar is furnished as standard equipment with the machine itself, so that this connection may be readily made. (See Cut No. 3391.)

We recommend that the balanced controlling wind valve be installed directly at the outlet of the blower, and operated from the bellows by means of a chain and pulley system. Cut No. 3391 shows this type of installation quite clearly, and if this is followed, a thoroughly satisfactory installation should result.

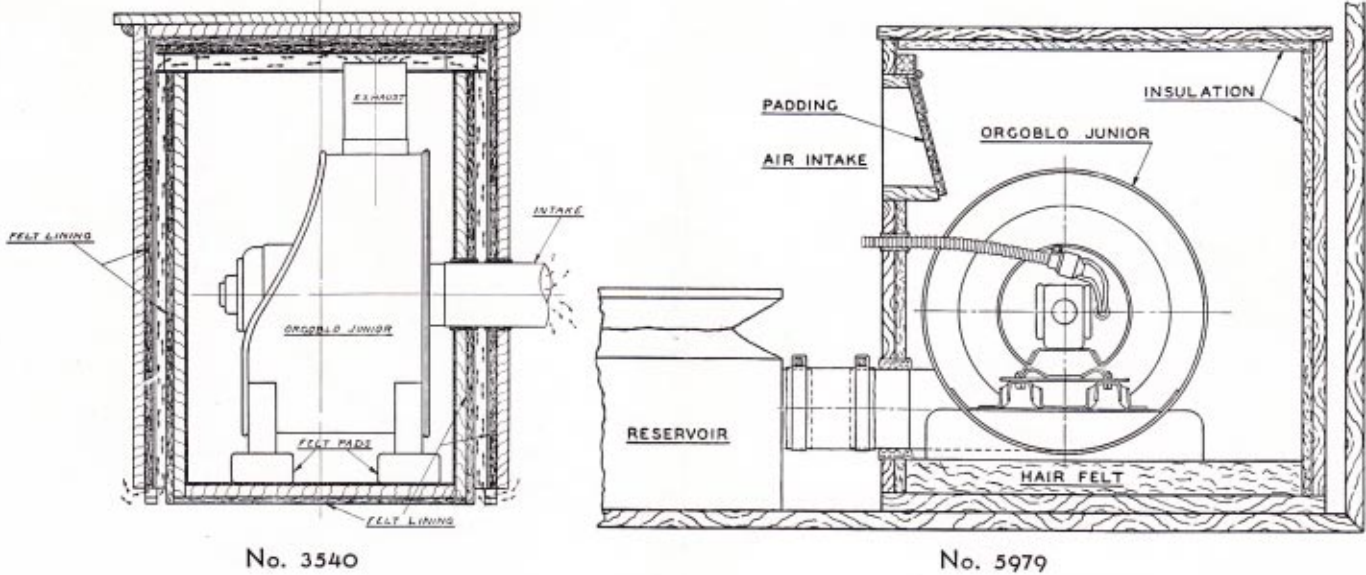

No. 3540

No. 5979

Sound Proof Enclosures

For the average installation it is not necessary to enclose the Orgoblo Junior other than perhaps to afford it sufficient protection from dust and dirt so that it may give the high quality of service for which it is designed. In all ordinary installations where the blower is installed in the basement beneath the organ or in other cases where it is installed in the adjoining room, the Orgoblo Junior is sufficiently silent in operation so that it is seldom heard at the console of the instrument. The preceding pages have discussed in considerable detail customary methods of installation and we are confident that the reader has found covered there all of the customary applications of Orgoblo Juniors to both pipe and reed instruments.

In those cases where it is found necessary to install the blower directly beside the instrument or perhaps more frequently where it is desired to place the blower within the case of the instrument, added precautions must necessarily be taken. Under these circumstances, we recommend that one of the specially quiet felt-lined machines be installed and in turn that an effective sound proof enclosure be included.

At the top of this page are shown two suggested means for enclosing these Orgoblo Juniors in a sound proof box. Cut 3540 shows a typical method where the

blower is used for suction. The enclosure consists of a wooden box of a double walled construction and is lined with some sound proofing material such as celotex, acousti-felt or others, which may be on the market today.

Drawing No. 5979 shows a similar installation where the blower is used on a pressure application. In this case by way of variety we are showing a single enclosure lined with similar material to that mentioned above.

In every installation provision must be made for the free access or discharge of air. In the case of a suction blower the exhaust from the instrument must escape from the enclosure freely and without friction, which naturally wastes power. In the case of a pressure blower, the air intake must be of ample size for the same reason.

It should be realized that the above are only offered as suggestions and that there are many other types of enclosures which are equally as good and just as effective. The principal things to remember in building a sound proof enclosure around any blower is that there should be ample openings to provide for the entrance or discharge of air and furthermore one side should be easily removed in order that the motor may be accessible for oiling and inspection periodically.



ORGAN POWER

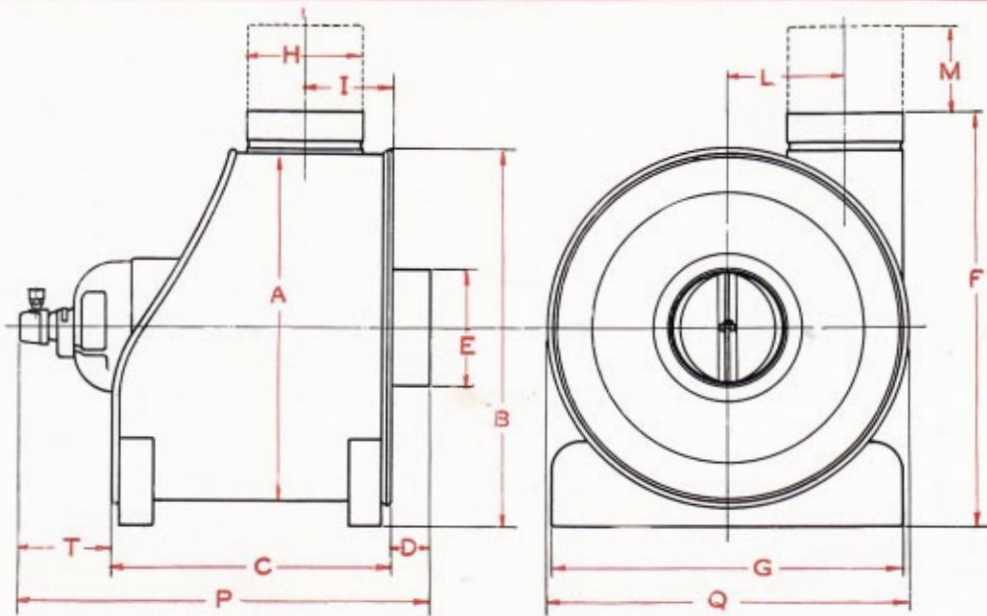

Capacities of Orgoblo Juniors

Pressure-Inches of Water		2 in.		2½ in.		3 in.		3½ in.		4 in.		5 in.		6 in.	
H. P.	Stages	Cat. No.	Vol.	Cat. No.	Vol.	Cat. No.	Vol.	Cat. No.	Vol.	Cat. No.	Vol.	Cat. No.	Vol.	Cat. No.	Vol.
1/8	1	J812	150	J812½	125	J813	100	J823½	85	J824	75	J825	60		
1/8	2							J613½	140	J624	125	J625	100		
1/6	1			J612½	200	J613	160			J414	185	J415	150	J636	85
1/6	2							J413½	200					J426	125
1/4	1									J314	250	J315	200	J316	155
1/4	2							J313	310	J313½	275				
1/4	3									J214	370	J215	310	J216	245
1/3	1							J213	490	J213½	430				
1/3	2														
1/3	3														
1/2	1														
1/2	2														
1/2	3														

Pressure-Inches of Water		7 in.		8 in.		10 in.		12 in.		15 in.		18 in.		20 in.	
H. P.	Stages	Cat. No.	Vol.	Cat. No.	Vol.	Cat. No.	Vol.	Cat. No.	Vol.	Cat. No.	Vol.	Cat. No.	Vol.	Cat. No.	Vol.
1/6	3	J637	70	J638	60	J6310	50								
1/4	1														
1/4	2	J427	100	J428	90	J4310	75	J4312	60	J4315	50				
1/4	3														
1/3	1	J317	125	J328	100	J3210	90	J3212	75	J3315	65	J3318	50	J3320	40
1/3	2														
1/3	3														
1/2	1	J217	215	J218	185	J2210	150	J2212	125	J2215	100	J2318	75	J2320	60
1/2	2														
1/2	3														

Approximate Dimensions in Inches

H.P.	Cat. No.	A	B	D	E	F	G	H	I	L	M	Q	Single Phase			Direct Current		
													C	P	T	C	P	T
1/8	J-812, J-813	12"	13¼"	2¼"	4	14¼"	12	4	3 1/16"	4	X	12¾"	11¼"	16	2¼"	11¼"	17¼"	3¼"
1/8	J-823½, J-825	12"	13¾"	5½"	4	14¼"	12	3	4¾"	4½"	X	13	12¼"	19¾"	1¾"	12¼"	20½"	2½"
1/6	J-612½, J-613½	14"	15¾"	3¼"	4	16¼"	14	4	3	5	4½"	14¾"	12¼"	16¾"	1	12½"	18	2¼"
1/6	J-624, J-625	12"	13¾"	5½"	4	14¼"	12	4	4¼"	4	4½"	13	12½"	19¾"	1¾"	12½"	21	3
1/6	J-636, J-637	12"	13¾"	5½"	4	14	12	3	3	4½"	X	13	11	18¾"	2¼"	11	20	3½"
1/6	J-638, J-6310	12"	13¾"	5½"	4	13¾"	12	2½"	3	4¾"	X	13	11	18¾"	2¾"	11	20	3½"
1/4	J-413½, J-414	14"	15¾"	4¼"	6	16¼"	14	4	3	5	4½"	14¾"	12½"	17¾"	1	12½"	19	2¼"
1/4	J-415	18"	19¾"	4	6	20¼"	18	4	3½"	7	4½"	19	12	18	2	12	19¼"	3¼"
1/4	J-426, J-428	14"	16¼"	6½"	6	16¼"	14	4	4	5	4½"	15½"	12½"	20	1	12½"	21¼"	2¼"
1/4	J-4310, J-4312	14"	16¼"	5½"	4	15¾"	14	3	3	5½"	X	13	13	19¾"	1¼"	13	21	2½"
1/4	J-4315	14"	16¼"	4¾"	4	15¾"	14	2½"	3	5¾"	X	13	13	18¾"	1¼"	13	20	2½"
1/3	J-313, J-315	18"	19¾"	7½"	10	21¼"	18	6	4½"	6	5¾"	19	16	24¾"	1	16	25¼"	1¾"
1/3	J-316, J-317	18"	19¾"	3½"	6	20¼"	18	4	3½"	7	4½"	19	14½"	18	X	14½"	18½"	1½"
1/3	J-328, J-3212	18"	19¾"	5½"	4	19¼"	18	3	4	7½"	X	19	14½"	21	1	14½"	21½"	1½"
1/3	J-3315, J-3320	18"	19¾"	5½"	4	18	18	2¼"	3½"	7½"	X	19	15	21¾"	1¼"	15	22¼"	1¾"
1/2	J-213, J-217	18"	19¾"	7½"	10	21¼"	18	6	4½"	6	5¾"	19	16	24¾"	1¼"	16	25¼"	1¾"
1/2	J-218	18"	19¾"	3½"	6	20¼"	18	4	3½"	7	4½"	19	14½"	18	X	14½"	18½"	1½"
1/2	J-2210, J-2215	18"	19¾"	6½"	6	20¼"	18	4	4	7	4½"	19	14½"	22	1	14½"	22½"	1½"
1/2	J-2318	18"	19¾"	5½"	4	19¼"	18	3	3½"	7½"	X	19	15	21¾"	1¼"	15	22¼"	1¾"
1/2	J-2320	18"	19¾"	5½"	4	18	18	2¼"	3½"	7½"	X	19	15½"	22¼"	1¼"	15½"	23	2



THE SPENCER TURBINE CO. - HARTFORD, CONN.

ORGAN POWER DIVISION

Printed in U.S.A.
2M-11-1-36