

# Spencer® Jet-Clean® Cartridge Separator



## Installation, Operation and Maintenance

Serial No.

Model No.

## Important

Read and become familiar with this manual prior to installing your Spencer Separator. Following the instructions detailed here will help you realize its full potential of efficient service and extended lifespan. Damage resulting from failure to follow correct procedures will void the warranty.

# Contents

Page

<b>I Introduction</b> .....	<b>2</b>
Product Description.....	2
<b>II Limited Warranty</b> .....	<b>2</b>
<b>III Safety Precautions and Operating Guidelines</b> .....	<b>4</b>
<b>IV Handling</b> .....	<b>4</b>
Shipment.....	4
Inspection .....	4
Unpacking.....	4
<b>V Installation</b> .....	<b>4</b>
Location.....	4
Separator Setup.....	5
<b>VI Operation and Adjustments</b> .....	<b>6</b>
Startup Precautions.....	6
Separator Startup.....	6
Normal Operating Limits .....	7
<b>VII Maintenance</b> .....	<b>7</b>
<b>VIII Troubleshooting Guide</b> .....	<b>8</b>

# Product Description

Components of a Jet-Clean Cartridge Separator include:

**Inlet section.** Dust-laden air enters the separator via the inlet section where its velocity is reduced. Heavier particles are separated by centrifugal force and gravity, and fall into the lower section. Lighter particles are carried upward and deposited on the outside of the cartridge filter. Cleaned air passes through the filter and out the discharge.

**Cartridge section.** The Jet-Clean Cartridge uses a pleated filter similar to an automotive air cleaner. While in use this filter is automatically, repetitively cleaned by powerful pulses of compressed air.

**Clean Air Plenum (CAP)** is the chamber at the top of the separator. The CAP contains or supports the Jet-Clean components that clean the dirty cartridges of their accumulated dust. The Jet-Clean devices include:

1. **Venturis**, one per cartridge, are air amplifying devices that augment the effect of the reverse pulse jet and direct air through the cartridges for effective cleaning.
2. **Solenoid Valves (A)**, acting upon signals from the timer, control the air diaphragm valves.
3. **Air Diaphragm Valves (B)** release pulses of high pressure air through the venturis to clean the filter cartridges.
4. **Air Header (C)** connects the air valves to a 90-100 psig compressed air source. The header also acts as a surge tank to maintain sufficient air volume at full pressure.
5. **Sequence Timer (D)**, located outside the separator in a NEMA 4 housing, is an electronic unit that determines the frequency and duration of filter cleaning.

## I. Introduction

Welcome as a Spencer customer and owner of a new Jet-Clean Cartridge Separator. This manual contains information for handling, installing, operating and maintaining your new equipment correctly, to ensure trouble-free operation and long service life. Please read it through carefully.

If you have any questions about the procedures or recommendations presented, call your Spencer Representative for advice. The Spencer Service and Engineering Departments are also available, through your local representative, to provide assistance.

Before proceeding with installation, be sure the model number and serial number are correctly recorded in the boxes on the front cover of this manual. Having this information easily accessible will expedite parts orders and other communication with the factory.

## II. Limited Warranty

We warrant that this product will be free from defects in material and workmanship for a period of 18 months from date of shipment or 12 months from date of startup, whichever comes first. Within the warranty period, we shall repair or replace, F.O.B. our Factory or authorized service centers, such products that are determined by us to be defective.

This warranty will not apply to any product which has been subjected to misuse, negligence or accident, or misapplied or improperly installed. This warranty will not apply to any product which has been disassembled, repaired or otherwise altered by any persons not authorized by the Spencer Service Department. For complete warranty information, including our limitation of liability, consult Spencer's Terms and Conditions of Sales.

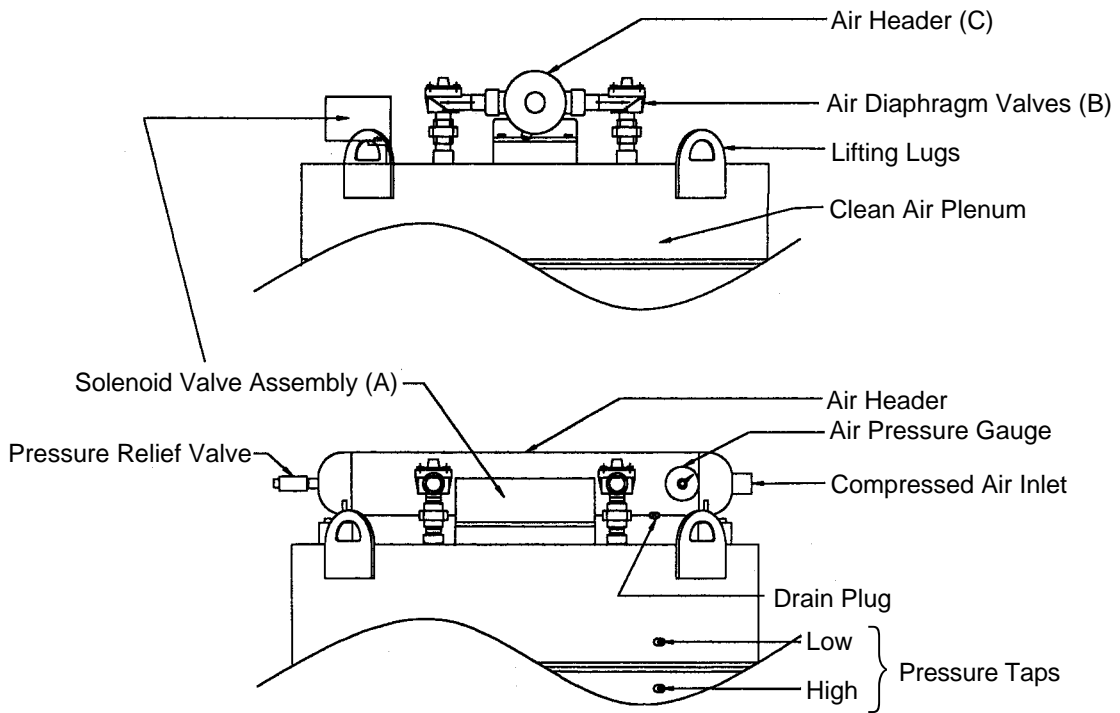
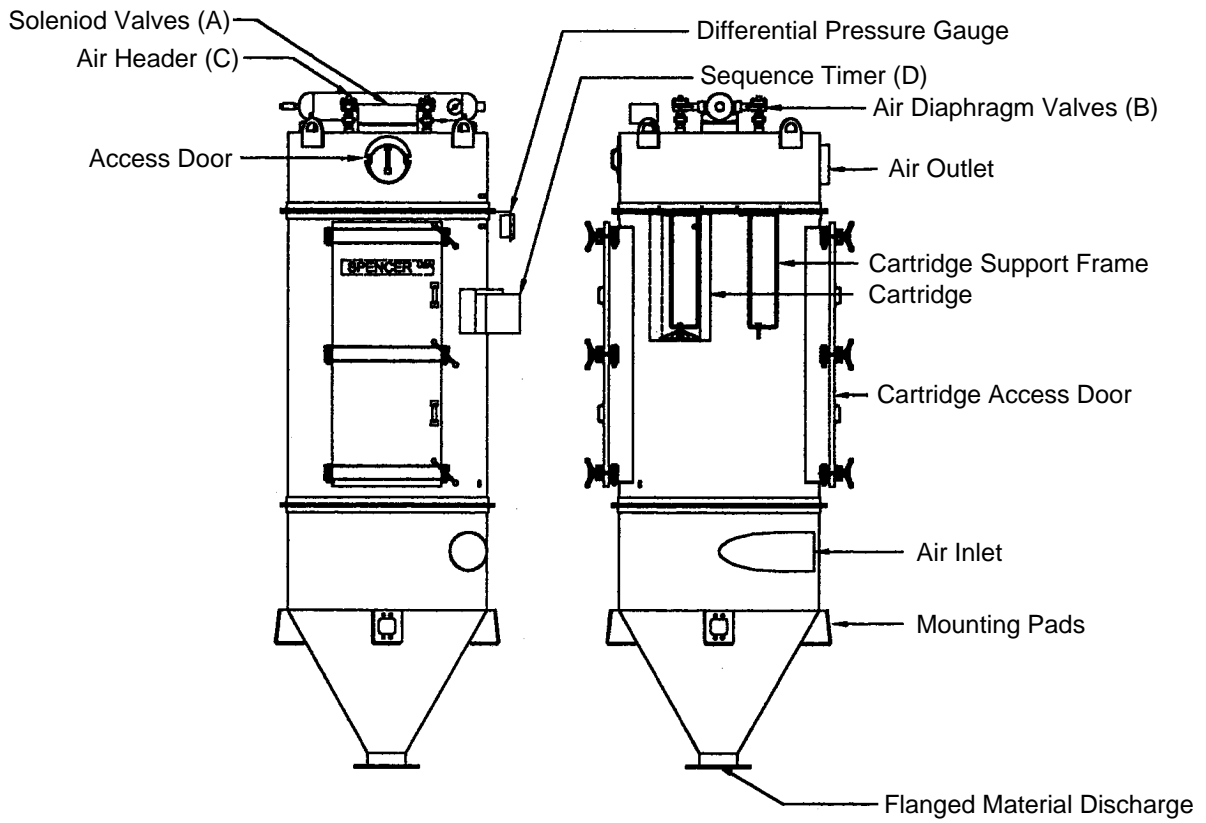

### Clean Air Plenum

# III. Safety Precautions and Operating Guidelines

- Read and follow all instructions in this manual. If you have any questions, consult your Spencer Representative.
- Perform all installing and operating procedures with care, following safe practices to avoid accidents and damage.
- Use adequately rated lifting equipment for installation, removal or disassembly of heavy components.
- Make sure the separator is securely bolted to the frame and the frame is bolted to the floor.
- Obtain approval by insurance carrier for installations involving flammable or explosive dust collection.
- Inspect all openings for objects and foreign matter before connecting accessories or piping.
- Install filter cartridges (shipped separately) in the separator after vertical installation and before startup.
- Check components and accessories for proper operation before startup.
- Do not vacuum burning materials into the separator.
- Lock electrical circuits open and tag them during servicing of equipment.
- Ensure that tubing and accessories such as filters or valves are properly installed and fastened.
- Use only genuine Spencer original equipment parts for repairs and replacements.

## IV. Handling

### Shipment

To minimize on-site assembly, Spencer separators are typically shipped assembled except for the filter cartridges. Air headers, solenoids, air piping, air pressure gauges and sequence timers are premounted, piped and ready for connection to compressed air and power supplies.

For protection during shipping, filter cartridges and their mounting hardware are shipped separately; these packages are clearly marked. If the separator is not installed immediately, the filter cartridges should be stored in a dry, indoor location.

### Inspection

Spencer separators are inspected and securely crated before shipment. Because damage may occasionally occur in transit, inspect the separator carefully upon arrival. Note any damage on the bill of lading. Damage incurred in transit is the responsibility of the common carrier, therefore damage claims should be filed against the carrier as soon as possible. Since Spencer ships F.O.B factory, any claims must be initiated against the carrier by the purchaser, as stated in Spencer's Terms and Conditions of Sales.

## Unpacking

1. Uncrate the separator, saving all literature, boxes and parts.
2. Remove inlet and discharge protective caps and all packing materials. Check inside the separator for loose parts.
3. Use the packing slip to check off and confirm the presence of all ordered components.
4. Read any instructional and warning labels on the separator before installation and operation.

## V. Installation

NOTE: If any problems are encountered during installation or startup, consult your local Spencer Representative.

### Location

The separator's exterior finish, a polyurethane topcoat over epoxy primer, is suitable for most environments. If the separator will be subject to corrosive atmospheres or other adverse conditions, additional protective coating may be required.

If the separator will be used to collect flammable dust or if there is an explosion risk, consider locating the separator outdoors.

**Caution: Your insurance underwriter should examine and approve any proposed installation when the application involves flammable or explosive materials.**

**Caution: If explosion relief vents are required, consult the NFPA or your insurance underwriter regarding proper venting requirements.**

**WARNING: IF EXPLOSION RELIEF VENTS ARE INSTALLED ON EQUIPMENT INSIDE A BUILDING, THEY MUST BE LOCATED NEXT TO AN EXTERIOR WALL AND PROPERLY VENTED TO THE OUTSIDE, TO AVOID DAMAGE TO EQUIPMENT OR PERSONNEL. CONSULT LOCAL CODE AND NFPA CODE.**

### Separator Setup

#### 1. Separator Installation

1. Mount separator on a suitable support frame.
2. Bolt separator securely to the frame and the frame to the floor.
3. Connect the inlet and discharge piping. Make sure the connections do not leak.

#### 2. Filter Elements

1. Carefully place the cartridge assembly over the cartridge support frame.
2. Using a gasket, two washers and wing nut, secure the cartridge to the support frame.
3. Turn the wing nut clockwise until the gasket is compressed about 1/4".

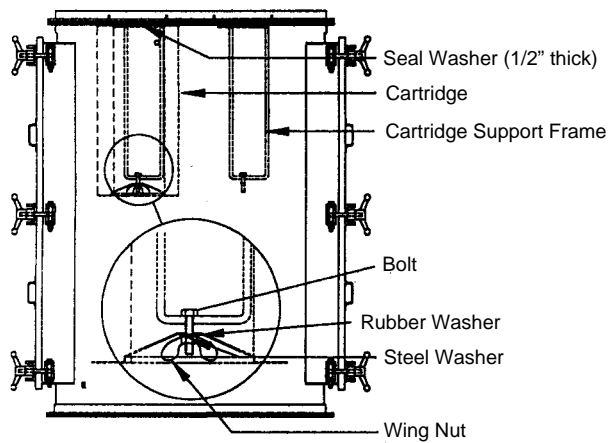

### 3. Differential Pressure ( P ) Gauge

All accessories and a detailed instruction sheet are packed with your gauge.

1. Mount the gauge in a location free from excessive vibration, where the temperature does not exceed 140°F (60°C). Avoid direct sunlight.
2. Connect the gauge using 1/4" plastic tubing and compression fittings or 1/4" copper tubing and fittings.
3. Place a loop in the high pressure line from the dirty air housing to keep dust out of the gauge line (see diagram below; also note the two additional, optional techniques shown).
4. Adjust the differential pressure gauge to zero reading when there is no flow through the separator.

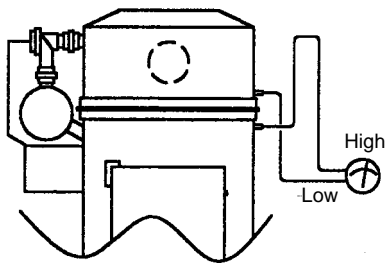

Loop in tubing (dirty air side) should be at least 12" higher than clean air connection to keep dust out of gauge line.

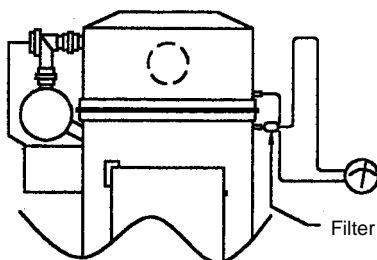

Small in-line filter (not provided) may also be used at inlet to dirty side tubing.

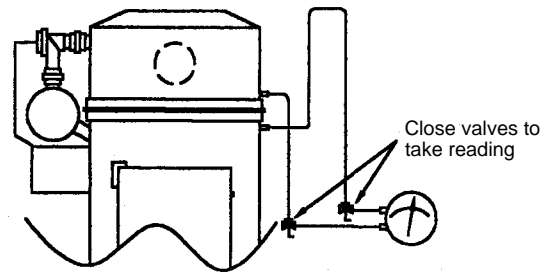

Optional setup with 3-way valves which bleed air continuously except when reading gauge; airflow minimizes dust plugging.

### 4. Discharge Valve

If an optional rotary feeder or other discharge valve has been supplied, it should be bolted to the discharge flange of the separator according to manufacturer's instructions.

### 5. Electrical

**CAUTION: All wiring and electrical adjustments or installations must be done by a qualified electrician in accordance with the National Electrical Code and local codes.**

NOTE: In addition to Spencer's standard NEMA 4 enclosure for the sequence timer and solenoids, optional NEMA 7/9 enclosures are also available.

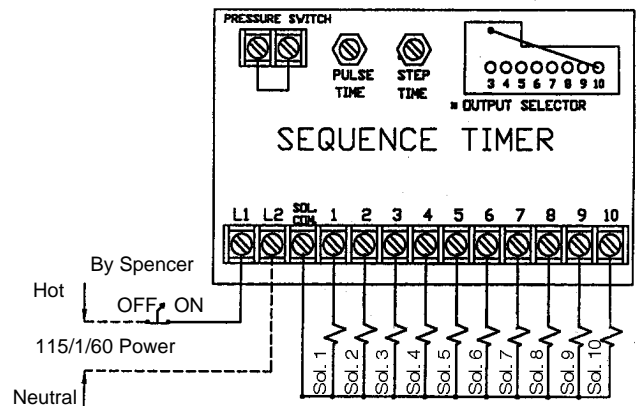

Connect 115 volt, single phase, 60 Hz, 10 amperes power supply to sequence timer terminals marked Line L1 and L2. In grounded systems, connect neutral of line to L2.

Interconnecting wiring between the sequence timer and solenoid valves is installed at the factory. In operation, the sequence timer signal starts at Solenoid 1, then activates Solenoid 2 and continues in sequence to the last selected solenoid, then recycles. Turning the sequence timer switch OFF, then ON, resets the sequence; the cycle begins again at Solenoid 1.

Sequence Timer adjustments are:

**Pulse Time**, duration of each air pulse, is factory preset at 100 milliseconds, adjustable from 50 to 500 ms via potentiometer (see diagram above).

**Step Time**, interval between pulses, is factory preset at approximately 20 seconds, adjustable from 8.5 to 180 seconds via potentiometer (see diagram above).

## 6. Compressed Air

Connect a source of clean, dry (instrument quality) compressed air to the air header. Air consumption is approximately 1.9 scfm per pulse when the pulse duration is 100 ms. The compressor and its piping must be adequately sized to deliver a constant pressure of 90 to 100 psig at the header, even with other users on line.

## 7. Optional Accessories

**Differential Pressure ( P ) Switch** senses pressure drop through the filter cartridge and activates the sequence timer. This switch should be connected to the pressure switch input terminals on the timer (see diagram on page 5). When the P rises to a preset point, the cleaning cycle is initiated. Cleaning continues until the differential pressure drops below the low set point.

Note: If a P switch is not used, the pressure switch terminals on the sequence timer should be shorted out with a jumper (see diagram on page 5).

**Airlocks** should be electrically interlocked to start simultaneously with the vacuum producer. They should also be furnished with a time delay to permit them (and the pulsing action of the separator) to continue for two to three minutes after the vacuum producer shuts down.

# VI. Operation and Adjustments

## Startup Precautions

Make an operational check of all components to detect any problems before the unit goes on line. Check the following:

**Sequence Timer.** When power is switched on, the red "power on" indicator should light. The individual timing lights should blink, one at a time, at the preset intervals.

**Solenoids.** Clicking of solenoid valves should be clearly audible during operation. Exhaust air from each valve can be felt at the discharge port when the valve is pulsed.

**Air Diaphragm Valves.** When actuated, each valve emits a blast of air that can be heard clearly.

**Cartridges.** Inspect cartridges to be sure:

Cartridges are tightly seated with proper gasket and washers.

Wing nut is hand-tightened securely.

**Tubing and/or Ductwork.** Be sure all connections are tight and all cleanout ports are closed. (Leaky tubing can result in poor overall system performance.) Tubing, piping and ductwork must be free of debris. Make sure access doors are closed. Check all gaskets for leakage.

**Blower or vacuum producer, airlock** and other accessories differ from system to system. Perform the appropriate checks, which may include:

Check for proper direction of rotation as marked on the equipment.

Inspect rotating equipment and remove foreign objects.

Be sure all guards and other safety equipment are in place.

**WARNING: KEEP HANDS OUT OF AIRLOCKS TO AVOID INJURIES.**

## Separator Startup

1. Close all doors and ports, with sequence timer and auxiliary equipment off.
2. Turn on compressed air to separator and inspect the jet pulse system for leaks. If air is leaking through any valve with the timer off, there may be a leak between the solenoid and diaphragm valve. Inspect the 1/4" tubing between the solenoids and diaphragm valves to be certain all connections are tight and leak-free. The tubing must not be crimped. Shut off compressed air supply.
3. Turn on sequence timer. The red "power on" indicator should light. Individual timing lights should blink, one at a time, at preset intervals. The corresponding solenoid valves will be activated; clicking of the solenoid valves should be clearly audible.
4. Turn the air supply to the air header on again. All solenoid valves should be cycling. Feel for the exhaust air from each valve.
5. Confirm the STEP time is between 10-20 seconds (preset at factory). This may be adjusted later, based on the dust loading in your particular system. Let the separator pulse for ten minutes to clear all lines.
6. Confirm that all dust discharge equipment such as rotary valves and conveyors is interlocked to start with the vacuum producer. If not, turn them on.
7. Start the vacuum producer with the butterfly valve set at about 50% of maximum airflow and allow equipment to run for 30 minutes.

Note: It is good practice to introduce the dust stream to new filters gradually. This is particularly true with very fine solids (less than 2 microns) or high dust concentrations.

8. Check vacuum producer exhaust line for dust. If present, shut off system and correct problem.
9. Observe the differential pressure gauge. At startup the pressure drop will be low, approximately 1/2" to 1" H<sub>2</sub>O. After 30 minutes of operation, the cartridges will start to coat with filtered dust. The filtering efficiency and differential pressure will increase. At this point, open the butterfly valve of the vacuum producer to its design setting.

10. Recheck the P gauge after the separator has run for several hours and the differential pressure has stabilized. If the P is below 3-4" H<sub>2</sub>O, gradually increase the STEP time (interval between pulses), using a screwdriver. If the P is higher than 4" H<sub>2</sub>O, decrease the STEP time. After each change, let the system stabilize before making further adjustments.

Note: A pressure drop of 3-4" H<sub>2</sub>O across the cartridge will generally provide good results although 1-6" is considered normal. With any new system, a certain amount of trial and error may be necessary for optimum operation.

The system is now ready for use.

## Normal Operating Limits

Temperature of the system must remain below the maximum temperature rating of the filter cartridges used in your separator. Check the information furnished with your cartridges for their characteristics and operating limits.

The differential pressure gauge must be located away from excessive vibration, where the temperature does not exceed 140°F (60°C). Avoid direct sunlight.

**WARNING: NEVER VACUUM BURNING MATERIALS INTO THE SYSTEM.**

---

## VII. Maintenance

**WARNING: DISCONNECT AND LOCK OUT ELECTRICAL POWER BEFORE PERFORMING ANY MAINTENANCE PROCEDURE.**

Your separator should provide many years of excellent performance. To assure trouble-free operation, perform the following preventive maintenance steps as indicated:

- |                  |                                                                                                                                                                                     |
|------------------|-------------------------------------------------------------------------------------------------------------------------------------------------------------------------------------|
| <b>Daily</b>     | Check timer, adjust if necessary.<br><br>Check the P gauge for pressure drop across cartridges.<br><br>Check for proper discharge of collected material from the separator.         |
| <b>Weekly</b>    | Check timer and solenoids for proper operation.                                                                                                                                     |
| <b>Monthly</b>   | Lubricate rotary airlock if present.<br><br>Inspect seals for dust leaks.                                                                                                           |
| <b>Quarterly</b> | Inspect cartridges for damage or leaks.<br><br>Inspect, clean or replace P gauge air filters.<br><br>Lubricate vacuum producer according to instructions in vacuum producer manual. |

During these regular checks, be alert to problems such as the following that may arise or become worse over time.

**Filter Blinding.** (Filter medium is filled with dust that cannot be removed by cleaning pulses.) Blinding is indicated by a high P that does not drop when the filters are pulsed for a period with the vacuum producer turned off. Two common causes are filter overloading and moisture pickup from the dust-laden air or the compressed air. Also, certain dusts have high blinding tendencies. If blinding is severe, consult your Spencer Representative for assistance and a possible change of filter media.

**Dust Re-entrainment.** (Dust loosened during cleaning redeposits on the filter medium.) Re-entrainment leads to unusually high filter loading and often a high pressure drop. One possible cause of re-entrainment is discharge hopper overflowing. There may be bridging of collected material in the hopper or an inadequate dust discharge system. Also, some types of dust are more susceptible to re-entrainment than others. Remedies may involve increasing the capacity of the dust discharge system, installing a high level alarm, adding a debridger in the hopper, and/or changing the filter medium.

# VIII. Troubleshooting Guide

<b>PROBLEM</b>	<b>Possible Cause</b>	<b>Corrective Action</b>
<b>EXCESSIVE DUST LEAKAGE</b>	• Improper cartridge installation.	Seat cartridge, gasket and washers properly and hand-tighten wing nut securely.
	• Holes in filter caused by abrasion or mechanical damage.	Replace cartridge.
	• Missing filter cartridge.	Install cartridge.
	• Dust in clean air plenum left from earlier leak in cartridge.	Clean plenum completely before restarting separator.
<b>INADEQUATE FILTER CLEANING</b>	• Insufficient air pressure.	Verify 90-100 psig air delivery at air header even with all users on line
	• Faulty air diaphragm valve operation due to foreign material from the air supply piping (especially in new systems).	Clean valve, blow down lines before connecting.
	• Malfunctioning solenoid valve due to dirt in the valve plunger.	Clean plunger.
	• Faulty sequence timer operation.	Check timer wiring.
	• Excessively long intervals between cleaning pulses.	Adjust timer potentiometer with screwdriver to reduce STEP setting.
<b>UNUSUALLY HIGH PRESSURE DROP</b>	• Excessive airflow.	Match system airflow to separator rating.
	• Low compressed air pressure.	Ensure 90-100 psig air is constantly available at the air header.
	• Moist air causing filter clogging.	Eliminate moisture in air supply.
	• Solenoid valve malfunction.	Feel for air pulses at discharge of each valve; clean or replace valve or solenoid if faulty.
	• Rotary valve air leakage caused by increased clearances due to wear.	Repair or replace airlock.
	• Blinding of filter medium due to excessive dirt load.	Decrease STEP interval.
	• Blinding of filter medium caused by mixture of dust and moisture.	Eliminate moisture in system airflow or compressed air.
	• Blinding of filter medium due to unusually fine or difficult dust.	Consult Spencer Representative for alternative filter medium.
	• Dust re-entrainment due to hopper overfilling.	Check dust discharge system; consider hopper debridger or high level alarm.
	• Defective or misadjusted sequence timer	Check timer operation and settings; readjust or replace timer.
	<b>SHORT CARTRIDGE LIFE</b>	• Cartridge temperature or chemical resistance not matched to actual operating conditions.
• Localized cartridge wear caused by excessive material buildup in hopper.		Check dust discharge system; consider hopper debridger or high level alarm.
• Blinding of filter medium.		See Blinding topics above.

**For the name and telephone number of your local Spencer Representative, call 1-800-232-4321.**

**The Spencer Turbine Company, 600 Day Hill Road, Windsor, CT 06095-4706**  
 Since 1892 moving air and gas for a cleaner environment  
 TEL 800-232-4321 ♦ 860-688-8361 ♦ FAX 860-688-0098 ♦ www.spencerturbine.com