

Spencer® Power Mizer® Multistage Centrifugal Cast Blowers

Operating and Maintenance Manual

Serial No.

Model No.

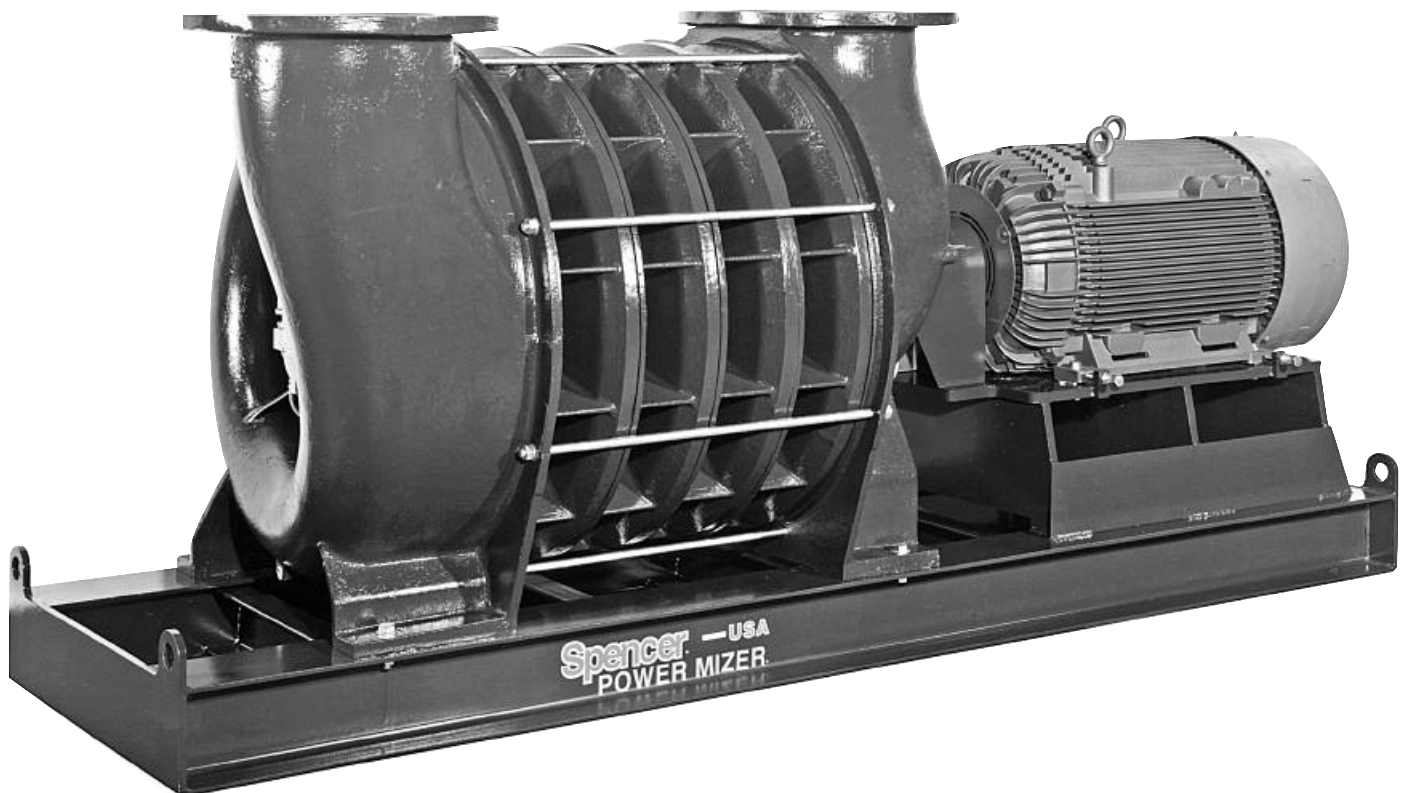

Important

Read and become familiar with this manual prior to installing your Spencer blower. Following the instructions detailed here will help you realize its full potential of efficient service and extended lifespan. Damage resulting from failure to follow correct procedure will void the warranty.

Contents

	Page
I Introduction	2
Product Description	3
II Limited Warranty	3
III Safety Precautions and Operating Guidelines	4
IV Handling and Storage	4
Lifting and Moving	4
Storage	5
Unpacking.....	5
V Installation	5
Location	5
Foundation.....	5
Blower Setup	5
1. Piping	5
2. Flexible Connectors	5
3. Butterfly Valve	6
4. Filters, Silencers and Filter Silencers.....	6
5. Check Valve	6
6. Electrical.....	6
7. Coupling Alignment	6
8. Bearing Lubrication	7
9. Shaft Seals.....	7
10. Motor Rotation.....	7
VI Operation and Adjustments	7
Startup Precautions	7
Blower Startup	8
Surge	8
Normal Operating Limits.....	8
Periodic Operation.....	8
Parallel Installation	8
VII Lubrication	8
Motor Bearings	8
Blower Bearings—Grease Lubricated	8
Blower Bearings—Oil Lubricated.....	9
Flexible Couplings	10
VIII Maintenance	10
Blower Bearing Removal and Replacement.....	10
Bearing Illustrations	11
Labyrinth Seal Removal and Replacement	12
Field-Replaceable Parts	13
Equipment Service	13
Material Safety Data Sheets.....	13
Emergency Service	13
Service and Operating Assistance.....	13
IX Troubleshooting Guide	13
Insufficient Air or Gas.....	13
Machine Noisy	14
Motor Hot.....	14
Vibrating Machine.....	15
Oil Leaks.....	15

I. Introduction

Welcome as a Spencer customer and owner of a new Power Mizer centrifugal blower. Your blower incorporates the latest engineering and casting technology, based on more than a century of Spencer leadership in blower design and manufacture.

This manual contains the information you need for handling, installing, operating and maintaining your new equipment correctly, to ensure trouble-free operation and long service life. Please read it thoroughly.

If you have any questions about the procedures or recommendations presented, call your Spencer Representative for advice. The Spencer Service and Engineering Departments are also available to provide assistance.

Be sure the machine model number and serial number are correctly recorded in the boxes on the front cover of this manual. These numbers may be found on the nameplate (see sample below) located on the blower discharge head.

Having this information easily accessible will expedite parts orders and other communication with the factory. To serve your maintenance and repair needs promptly, Spencer maintains a large inventory of parts for all blower models. Field-replaceable parts are listed on page 13.



Spencer® Power Mizer® Blower

Read instruction manual before handling and starting equipment.

Serial No. Model No.

Manufactured under the following –
Registered Trademark: 62,801; 140,976; 652,701;
1,854,029; 134,026; 341,418; 1,348,270; 959,254

The Spencer Turbine Company, Windsor, CT 06095
860-688-8361

Made in U.S.A.

Plate No. PLN-90055

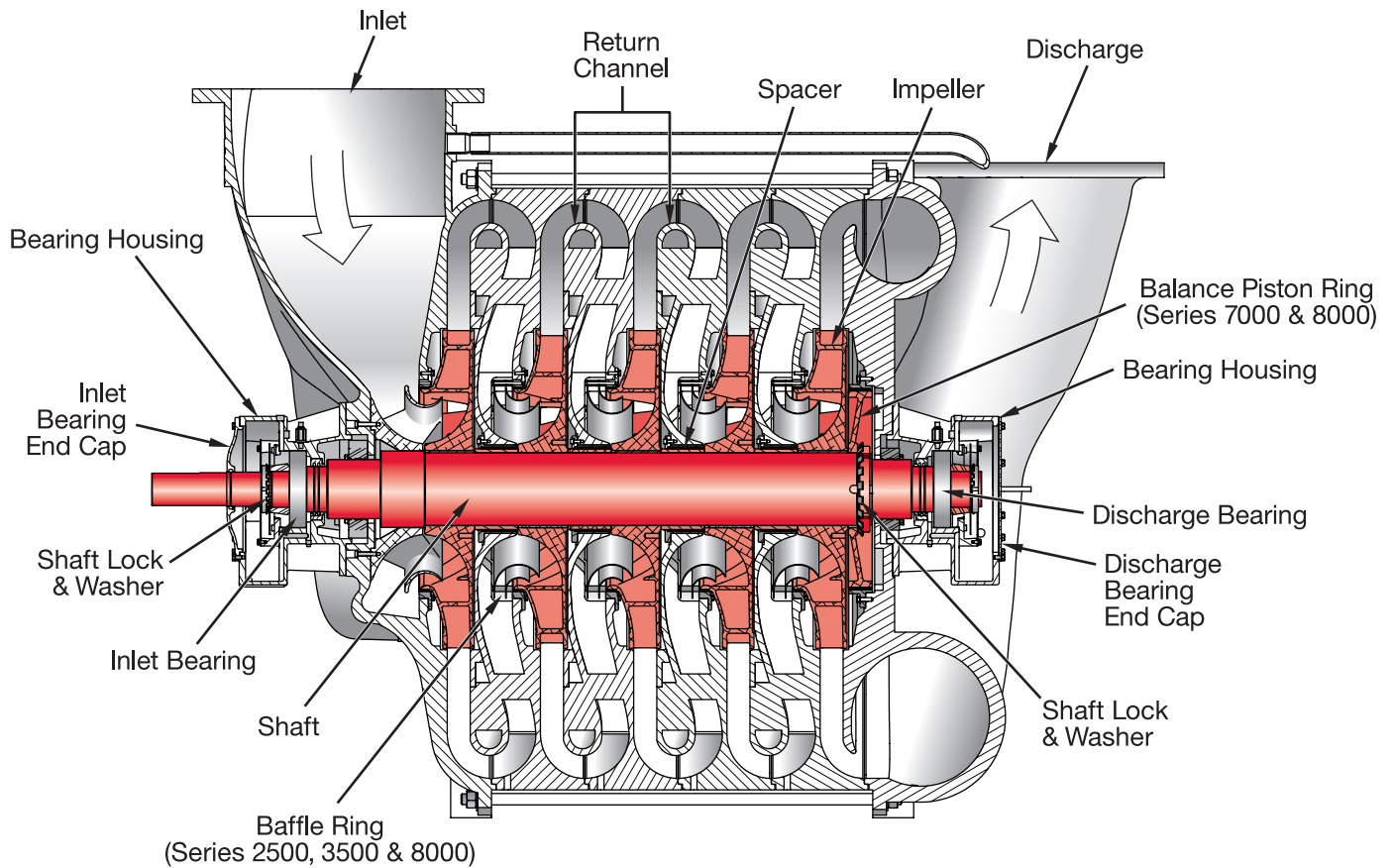

Product Description

Spencer Power Mizer blowers are multistage centrifugal units which handle air and other gases, working either as blowers or exhausters. They increase the pressure of the incoming air or gas by guiding it from one stage to the next through diffusers. They are centrifugal because the flow through the blower is turned perpendicular to the axis of rotation.

The blower casing has three main sections constructed of cast iron: inlet, return channels and discharge. The inlet and discharge are flanged and drilled to ANSI 125#/150# standards. External steel tie rods hold the return channels between the inlet and discharge sections. There are no external moving parts except the shaft that connects to the power source—typically an electric motor, but other drivers such as a steam turbine or internal combustion engine are available.

The internal rotor assembly consists of a steel shaft supporting cast aluminum alloy impellers with varying combinations of radial and backward curved blades. The impellers are individually dynamically balanced, then keyed to the shaft and the impeller/spacer stack is secured with a locknut. Finally, the complete rotor assembly is checked to be sure the total amplitude of vibration is no more than 0.23 in/sec at the bearing housing.

The rotor assembly is supported at both ends by antifriction bearings designed for an L-10 bearing life of 100,000 hours. Depending on intended blower use, either labyrinth seals or carbon ring seals are provided. See page 7 for Shaft Seal discussion.

Series 7000 and 8000 blowers are also equipped with an internal balance piston. As the largest Power Mizer models, these blowers develop high differential pressures with correspondingly high thrust loads. The balance piston is designed to lessen the thrust load, protecting the bearings from overloading.

II. Limited Warranty

We warrant that this product will be free from defects in material and workmanship for a period of 18 months from date of shipment or 12 months from date of startup, whichever comes first. Within the warranty period, we shall repair or replace, F.O.B. our Factory, such products that are determined by us to be defective.

This warranty will not apply to any product which has been subjected to misuse, negligence or accident, or misapplied or improperly installed. This warranty will not apply to any product which has been disassembled, repaired or otherwise altered by any persons not authorized by the Spencer Service Department.

The guarantees of the motor, control and component manufacturers govern the extent of our guarantee on such equipment. Warranty work on motors, controls and components must be authorized by Spencer and must be performed in an authorized shop as designated by the motor, control and component manufacturers. The Spencer Turbine Company reserves the right to invoice all expenses incurred when repairs are made in the field at the specific request of a customer.

III. Safety Precautions and Operating Guidelines

- Read and follow all instructions in this manual. If you have any questions, consult your Spencer Representative.
- Use appropriately rated lifting equipment for installation, removal, or disassembly of heavy components.
- Remove inlet and discharge covers, silica gel bags and crating materials prior to blower installation.
- Inspect all openings for tools and foreign matter before connecting accessories or piping.
- Perform all installing and operating procedures with care, following sound practices to avoid accidents and damage.
- Avoid climbing on or over the blower; use proper staging and ladders for exterior machine access.
- Be sure isolation pads are correctly located beneath the blower base. See page 5.
- Confirm that the blower is level so that oil level readings will be accurate.
- Install flexible connectors on inlet and discharge flanges to isolate piping loads from the blower.
- Ensure that piping, machine guards and accessories such as filters or valves are properly installed and fastened.
- Fill oilers of oil-lubricated blower bearings with recommended type of fresh oil as instructed on page 7.
- Install a filter on the inlet when the blower is used in pressure service and keep it clean.
- Allow only qualified electricians to work on electrical equipment.
- Lock electrical circuits open and tag them during servicing of equipment.
- Align the coupling as instructed on page 6.
- Remove alignment tools and replace coupling guard before restarting blower.
- Turn the blower shaft by hand to verify free rotation without rubbing or noise.
- Check motor rotation as instructed on page 7.
- Do not operate the blower where there is an ambient temperature above 104°F (40°C), unless it has been designed for such conditions.
- Operate blower with sufficient restriction at all times (via connected piping system or throttled butterfly valve) to avoid motor overloading.
- Do not allow blower operation in surge (unstable low flow) or damage may result.
- Rotate shaft of stored or inactive blowers a few times by hand every week.
- Use only genuine Spencer parts for repairs and service.

IV. Handling and Storage

Each Spencer blower is carefully balanced and tested at the factory. For optimum performance, it must be handled with care during unloading and installation.

Check the shipment for damage upon arrival; file any claims with the shipper and notify Spencer.

Lifting and Moving

Moving of this equipment is the customer's responsibility and should be performed or directed by experienced riggers using accepted rigging practices and safety precautions. The blower/motor assembly can be lifted and relocated with an overhead crane or hoist. Always use lifting equipment rated for the loads involved—see accompanying table of approximate machine weights.

CAUTION: Use of alternative lifting methods such as a forklift is not recommended, due to risk of equipment damage or misalignment.

Approximate Machine Weights
(blower and base without motor)

Model No.	Weight		Model No.	Weight	
	lb	kg		lb	kg
C13	177	80	C43	3065	1390
C14	188	85	C45	4050	1837
C15	200	91	C46	4517	2049
CS22	913	414	C47	4976	2257
CS23	1101	499	C48	5446	2470
CS24	1290	585	C52	3543	1607
CS25	1478	670	C53	4294	1948
CS26	1667	756	C54	5001	2268
CS27	1855	841	C55	5708	2589
CS28	2044	927	C56	6428	2916
CS29	2232	1012	C57	7135	3236
CS210	2421	1098	C58	7810	3574
C32	1917	870	C62	4577	2076
C33	2225	1009	C63	5559	2521
C34	2596	1178	C64	6515	2955
C35	2928	1328	C65	7473	3389
C36	3285	1490	C66	8431	3823
C37	3688	1673	C72	10150	4604
C38	4004	1816	C73	12100	5489
CS32	2130	966	C74	14600	6623
CS33	2673	1212	C75	17200	7804
CS34	3196	1450	C76	20300	9207
CS35	3730	1692	C81	14500	6577
CS36	4263	1934	C82	18000	8165
CS37	4795	2175	C83	21500	9752
CS38	5328	2417	C84	25000	11340
CS39	5861	2659	C85	28500	12927
C42	2576	1169	C86	32000	14515

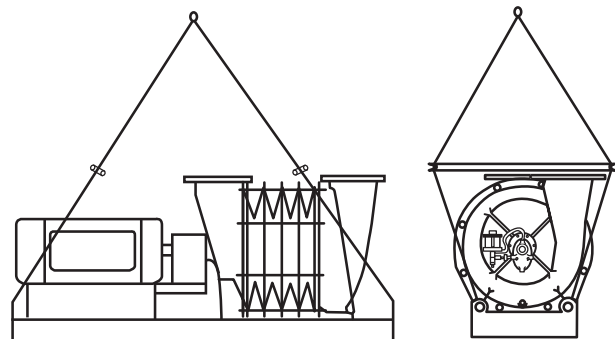

Use lifting eyes supplied on the blower base, along with a suitable quad leg chain sling or spreader bars with the smallest practical angle between the sling legs to minimize stress.

CAUTION: Do not use slings around the blower; they will bend or stress the tie rods. Never lift the blower by its shaft. Do not disturb the oilers or any electrical devices.

Storage

If a blower is stored for an extended period before use or between uses, protect it from dampness, dirt and vibration. Suspend bags of silica gel desiccant in the inlet and discharge. Cover the entire blower if possible or at least cover the inlet and discharge openings to keep out foreign matter. Rotate the blower shaft a few times by hand every week, keeping a log.

CAUTION: Failure to comply with the required storage provisions, including weekly shaft rotations, will void the warranty.

Unpacking

1. Uncrate the blower, saving all literature, boxes and parts.
2. Remove inlet and discharge protective caps and all packing materials.
3. Use the packing slip to check off and confirm the presence of all ordered components.
4. Read any instructional and warning labels on the machine before installation and operation.

V. Installation

NOTE: If any problems are encountered during installation or startup, consult your local Spencer Representative.

Location

CAUTION: Do not locate blower or controls where they will be subject to ambient temperatures above 104°F (40°C) during operation, unless specially equipped for higher temperatures.

Power Mizer blowers may be installed outdoors, preferably under cover, or indoors. When choosing an indoor location, be sure there is sufficient ventilation to allow unrestricted air-flow to the blower. In addition, it is advisable to leave several feet of space around the blower and motor for ease of servicing. Inaccessibility can prove costly.

Consideration should be given to the noise generated by this equipment and its contribution to the ambient noise level. Optional noise reduction accessories include blower casing sound attenuation jackets, filter silencers or silencers for the blower inlet and/or discharge, and silencers for the motor.

NOTE: Duct noise attenuation is a customer responsibility.

Foundation

CAUTION: Oil-lubricated machines must be level or oil level readings will be inaccurate.

A level concrete pad is recommended, although any flat level surface that can support the machine weight is satisfactory. The blower base should be placed level on the furnished isolation pads or equivalent. The number and location of pads are important. Pads must be located directly under a support for maximum performance. Locate one pad under each supporting member of the blower.

Locate the motor pads under the vertical motor base supports, not necessarily directly under the motor feet. Four pads per side will avoid any springboard effect. Each pad must be shimmed, if necessary, to ensure that it is carrying its share of the load. If lag bolts and nuts are used to restrain the blower, hand-tighten only.

NOTE: Spencer does not favor grouting; however grouting may be used consistent with established practice. Do not use isolation pads when grouting.

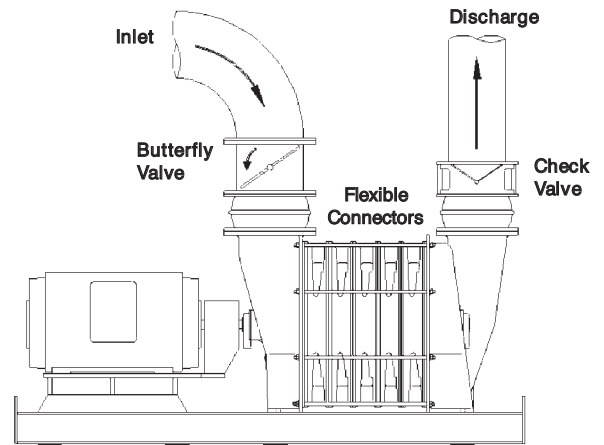

Recommended Pad Locations

Blower Setup

CAUTION: Make sure blower inlet and discharge ports are unobstructed before connecting piping to blower.

1. Piping

All piping connected to the blower should be of ample size to minimize frictional loss. All system joints must be airtight; leaky pipes waste air and power.

All piping must be properly aligned and supported to avoid stress on the blower and restrained to prevent movement away from the blower caused by air pressure. Flexible connectors must be used to connect piping to the blower.

NOTE: The diagram above shows the proper orientation of a piping elbow in-line with the blower shaft. The butterfly valve should have its shaft at right angles to the blower shaft and the valve should open as indicated (counterclockwise in this example). These steps will assure uniform loading of the blower's first stage.

2. Flexible Connectors

CAUTION: Connected piping must not touch the blower. Use flexible connectors (expansion joints or rubber sleeves) on both the inlet and discharge to create an isolating gap between blower and piping.

3. Butterfly Valve

To regulate (throttle) blower volume and/or pressure, a butterfly valve may be installed—preferably on the inlet. A valve may also be installed on the discharge as an isolation valve.

4. Filters, Silencers and Filter Silencers

Spencer blowers will accept a filter or filter silencer, typically on the inlet, and a silencer, typically on the discharge. Inlet filtration is recommended for pressure applications.

5. Check Valve

CAUTION: A check valve must be installed in the discharge line (downstream of any blow-off line) of each blower operating in parallel, or in the inlet line (upstream of any bleed line) of each vacuum producer operating in parallel to prevent reverse flow through idle units.

Orient the check valve during installation to equalize loading on the valve shutters. Usually, the hinge post of the check valve should be installed perpendicular to the blower shaft. If the check valve is installed in a horizontal piping line, position the valve shaft vertically. Make sure the internal moving parts can move freely.

6. Electrical

NOTE: All wiring and electrical adjustments or installations must be done by a qualified electrician in accordance with the National Electrical Code and local codes.

CAUTION: The electrical service at the installation site must supply the voltage stamped on the motor nameplate. Operation at an incorrect voltage may damage the motor and void its warranty.

Electrical Accessories. The following optional safety accessories are available from Spencer. For copies of the product bulletins listed, contact your Spencer representative or www.spencerturbine.com.

- Load Control Safety Switch (LCSS) – Bult. No. TDS-223
- Electronic Modulating Bleed Control (EMBC) – Bult. No. TDS-224
- Bearing Temperature Monitor Control (BTMC) – Bult. No. TDS-222
- Standard Blower Safety Control Panels (LCSS, BTMC and VM, Vibration Monitor) – Bulletin No. TDS-237 and TDS-236

NOTE: Use of a BTMC, vibration monitor and an LCSS or EMBC may be advisable in crucial or unattended applications, anywhere there are wide load fluctuations, or where machines are operating at high pressure or vacuum.

Both the LCSS and EMBC are designed to prevent a blower or vacuum producer from operating in a low load (surge) condition.

7. Coupling Alignment

Good coupling alignment is critical for smooth machine operation. **Pre-startup alignment is necessary and is a customer responsibility.** Spencer recommends that each blower be field aligned using a laser alignment system. Only qualified personnel, following the laser equipment manufacturer's instructions, should attempt coupling alignment.

WARNING: DISCONNECT AND LOCK OUT ELECTRICAL POWER BEFORE PERFORMING ALIGNMENT.

Machinery Soft Foot

Imperfections or unevenness between the machine base and any foot of the motor or blower creates a condition known as soft foot, which may be parallel or angular. If uncorrected, soft foot leads to increased stress and high vibration. Although both the motor and blower feet were preset at the factory, each foot must be checked for soft foot prior to alignment. Any vertical or angular soft foot that exceeds .003" is excessive and must be corrected.

Laser Alignment Technique

Laser alignment is the only method Spencer uses and the only one it recommends. Laser aligned systems have significant advantages such as reduced maintenance costs and energy consumption; prolonged life for bearings, seals and couplings; decreased bearing temperatures and lower vibration levels. Many laser systems also identify and measure soft foot conditions.

NOTE: Consult an alignment specialist if laser equipment is not available.

Coupling Gap Adjustment

Use of a laser system eliminates the need to “break” the coupling halves. The coupling gap may be left at the factory setting. (Kop-Flex model “B” coupling gaps are 1/8" up to size 2-1/2" and 3/16" for sizes over 2-1/2".)

Alignment should be performed at normal operating temperatures. Recommended factory tolerance is $\pm .004$ " parallel and $1/4^\circ$ angular at operating conditions.

Alignment Tips

- Make sure the blower is level before alignment.
- Mark the axial location of the motor before alignment as a reference point to be sure it does not move.
- Avoid disturbing any factory-installed shims unless they are to be replaced.
- Do soft foot corrections first; loosen all mounting bolts before correcting any foot.
- During the final vertical adjustment of the motor, work on one side at a time, loosening the jack bolts first so the motor does not move laterally as mounting bolts are loosened.
- Use the smallest shim that will slide over the mounting bolts.
- Minimize the number of shims. One thick shim and 2–3 thin shims are usually satisfactory.
- Remove all traces of dirt or contaminants from shims and machine parts.
- Use stainless steel shims only.
- Never reuse shims.

CAUTION: After each alignment check, add coupling lubricant if required.

Coupling Lubrication (grease lubricated)

Two coupling lubrication ports are located 180° apart. Remove the setscrew lube plugs from both ports. Install grease fitting in one port and rotate the coupling until the grease fitting is angled down at 45° . Pump lubricant in until it appears at the upper port. Remove the grease fitting; replace and tighten the lube plugs.

WARNING: REPLACE THE COUPLING GUARD BEFORE RESTARTING THE BLOWER.

8. Bearing Lubrication

Motor Bearings. Follow the motor manufacturer's recommendations. Some motors are equipped with sealed bearings not intended for relubrication; these motors have no grease or drain plugs.

Blower Bearings—Grease Lubricated. These bearings are packed at the factory and do not need greasing prior to start-up. If, however, the blower has been stored for three months or longer, remove the bearing caps and check for moisture or hard grease. Discard any hard or dry grease and relubricate if necessary.

Blower Bearings—Oil Lubricated. The type and quantity of oil are very important. Use only Mobil SHC626 synthetic oil or one of these equivalents:

- Exxon TRESSTIC® SHP synthetic oil, ISO Grade 68
- Amoco Syntholube SL compressor oil, ISO Grade 68
- ROYCO® synthetic compressor fluid #468
- Royal Purple Synfilm Grade 68

CAUTION: Do not mix oils; thoroughly drain the bearing sump and oiler before changing to a different brand of oil.

Constant Level Oilers

Some Spencer oil-lubricated blowers are equipped with constant level oilers (one each bearing housing). These maintain an established oil level by replacing the oil lost through seals, vents and various components in the bearing housing and sump. The oiler itself is replenished by periodically refilling the reservoir (upper portion of the oiler).

NOTE: Constant level oilers cannot reduce oil levels that are too high.

Because maintenance of the correct oil height is critically important, Spencer constant level oilers incorporate a tubular spout fitted with a view port and oil level scribe line.

Use only approved lubricants.

See Section VII on Lubrication for verifying the correct oil height.

9. Shaft Seals

Shaft seals at both the inlet and discharge ends minimize leakage of gas into or out of the blower. Cast aluminum labyrinth seals are standard; single and double carbon ring seals are optional.

NOTE: Series 2500 and 3500 blowers intended for gas service are equipped with an inlet end single carbon ring shaft seal and a discharge end sealed bearing housing.

Blowers equipped with double carbon ring seals have purge connections extending from each bearing housing which must be connected to a supply of nitrogen or filtered shop air. The supply should be regulated so the purge gas pressure at both the inlet and discharge is approximately 0.5 PSI greater than the process pressure.

NOTE: Blower inlet and discharge pressures are different, therefore purge pressures at the inlet and discharge seals should be established and regulated separately.

CAUTION: Do not operate double carbon ring seals without a properly pressurized purge connection. This will render the seal ineffective and could damage it.

10. Motor Rotation

A rotation arrow is located on the blower casing. "Bump" or jog the start button and observe the direction of rotation of the motor shaft. Rotation must be counterclockwise as viewed from the discharge end. If the rotation is incorrect, the motor wiring must be changed.

VI. Operation and Adjustments

Startup Precautions

Before operating a new blower for the first time, review its installation and setup to be sure that no steps have been overlooked.

1. Installation Check List

- Is there any damage from transportation or installation, especially to the oiler and oiler bracket?
- Is the machine level?
- Are the oilers level and is the oil height set correctly? (Oil lubricated blowers only)
- Have all packing, shipping materials and tools been removed?
- Is the inlet filter in place?
- Are isolation pads in place?
- Is the piping connected and supported?
- Are flexible connectors in place between blower and piping?
- Are safety guards in place?

2. Adjustment Checks

- Are the oilers filled? (Oil lubricated blowers only)
- Is the coupling aligned within tolerances?

3. Operational Checks

- Is the throttling valve closed or properly positioned?
- Do the blower shaft and driver spin freely?
- Is the isolation valve (if any) open?
- Is the system ready for air or gas delivery?
- Has rotation been checked?
- Are motor and electrical accessories properly wired?
- Is the control panel energized?
- Have maintenance and operations personnel been notified?

CAUTION: This blower must have adequate system resistance at all times to avoid operation at or near free delivery (wide open). It is typically imposed by the process and supplemented with a throttling valve. Running the blower overloaded will damage the motor.

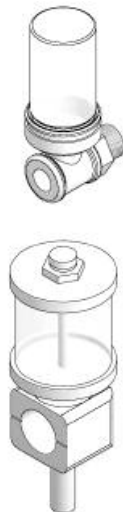

Blower Startup

With the system connected and the throttling valve closed, turn the blower on. Quickly assess the current draw of the motor. Adjust the system load or throttling valve until the desired flow is reached, being careful not to exceed the full-rated motor capacity. Initially, blowers will temporarily develop more differential pressure and take more power. Check final settings after operating temperature is achieved, typically after one-half hour. If the throttling valve is not fully open when the motor capacity has been reached, it should be fixed at this point to prevent further opening and possible overloading of the motor.

1. Surge

CAUTION: Do not operate blower in surge (unstable low flow range). Damage to blower caused by operating in surge is not covered by Spencer warranty.

A blower in surge produces a rush or pulsating rhythmic air sound caused when airflow into or out of the blower is restricted. In addition to its characteristic noise, surge may be detected by power or pressure fluctuations. Surge is potentially destructive because it is accompanied by excessive temperatures and aerodynamic forces that will ultimately cause mechanical failure. A surge condition is simply eliminated by increasing the airflow either into the system or to a bypass or vent. Various surge control devices are also available from Spencer—see page 6.

NOTE: If a blower surges violently at startup, avoid recurrences by leaving the throttling valve open at or near its normal operating position.

2. Normal Operating Limits

NOTE: Use of a Spencer bearing temperature monitor and vibration monitor is recommended to alert personnel to blower operation outside the following limits.

- Vibration should not exceed 0.23 in/sec at the bearing housing.
- Bearing temperatures should not exceed 220°F (104°C) at the bearing housing surface.

If abnormal operation is detected, shut the blower down and refer to the Troubleshooting Guide on page 14 or contact Spencer.

3. Periodic Operation

CAUTION: All blowers should be operated periodically.

In multiple blower installations, periodically rotate each blower from standby to operating status.

4. Parallel Installation

CAUTION: A check valve must be installed in the discharge line of each blower or inlet of each vacuum producer operating in parallel to prevent reverse flow through idle units.

CAUTION: Do not operate centrifugal blowers in parallel with positive displacement blowers. Such operation may damage the centrifugal blowers and will void the warranty.

When operating two or more blowers in parallel (typically identical blowers), each must carry its share of the load. The current readings of all motors should be approximately the same. It may be necessary to readjust the individual throttling valve stops to attain similar readings.

VII. Lubrication

WARNING: DISCONNECT AND LOCK OUT ELECTRICAL POWER BEFORE PERFORMING LUBRICATION.

CAUTION: Maintain extreme cleanliness to avoid bearing contamination and damage.

Motor Bearings

Follow the motor manufacturer’s recommendations. Some motors are equipped with sealed bearings not intended for relubrication; these motors have no grease or drain plugs.

Blower Bearings—Grease Lubricated

Use Chevron SRI #2 grease. Intermixing incompatible greases or using any other type may result in bearing failure which is not covered under the Spencer warranty.

Chevron SRI #2 Grease Specifications

Grade or consistency	#2
Thickener	polyurea
ASTM Dropping Point	480°F
Work Penetration	270
Base Oil Viscosity.....	600 SUS @ 100°F
Color	Blue-Green

Relubricate approximately every six months, according to the following table.

Recommended Lubrication Intervals

Normal Conditions	Extreme Conditions*
4000–5000 hours	2000–3000 hours

*Excessive heat, moisture, dust or corrosive conditions.

NOTE: More bearing failures are caused by overgreasing than lack of lubricant. Add grease sparingly and only when the bottom drain plug is open.

CAUTION: Keep the grease clean; any dirt or contaminants will damage the bearings.

1. Remove the bottom drain plug.
2. Probe the drain with a clean rod to free hardened grease.
3. Inject new grease only until old grease appears at the drain. NOTE: Some housings have two grease fittings.
4. Restart the blower with the drain plug still removed to allow excess grease to escape.
5. After normal operating temperature is reached, replace the drain plug.

Lubrication of replacement bearings. Before installing, “butter” both sides of replacement bearings by forcing grease into each side until the grease is flush with the race.

Blower Bearings—Oil Lubricated

General Oil Lubrication Information

CAUTION: If equipped with oiler, keep the oiler at least 1/3 full at all times.

Use Mobil SHC626 synthetic oil or equivalent (see list, page 7).

Each blower is shipped with an adequate amount of Mobil SHC626 oil for one oil change. The oil should be changed at least once a year.

1. Drain oil (preferably when hot) by removing the drain plug in the bearing sump.
2. Replace drain plug, fill the oiler and tighten the oiler screw cap finger tight. See Oil Filling section on page 7.

CAUTION: A loose or overtight screw cap will cause oiler malfunction. Do not distort the cap O-ring by overtightening.

Oiler Tips

There are several O-rings and gaskets in the oiler; leaks at any point can cause trouble. For example, if there is a leak in the oiler reservoir, the oiler will overfill the bearing sump.

Keep the oiler parts clean—dirt or contamination can initiate a leak.

Air leaks above the oil level do not produce bubbles, even as the oil feeds.

Pressures in the oiler and oil sump must be equal. Do not remove the vent line while the blower is operating.

Bench Testing Oilers

Use the following procedure to trouble-shoot malfunctioning oilers that exhibit oil leaks or overfilling.

1. Secure oiler so it is level in all directions.
2. Plug outlets with pipe plugs.
3. Remove fill cap and fill reservoir completely.
4. Quickly screw fill cap back on reservoir.

NOTE: When you close the fill cap, the check valve opens, allowing oil to fill the view port.

5. When the fill cap is tightened securely, the oil in the view port should seek a level at or near the level mark scribed in the casting.

Let the oiler sit for several hours. If oil fills the view port completely and is seeping out the vent hole, the seals are bad. The oiler needs to be repaired or replaced.

Series 2500, 3500

Oil Height Settings

Power Mizer Series 2500 and 3500 blowers have nonadjustable oilers hard-piped directly into the sump. There is no need to check oil height settings but make sure the sump and oiler are level.

Filling Oilers

Replenish oil in the reservoir only after it drops below half full, which will reduce the number of refills. If the oiler needs frequent filling, this is not normal—look for an oil leak.

Note: Oilers ‘nuisance feed’ as the reservoir is screwed off and on, which can lead to an overfilled sump. Screw on the oiler reservoir quickly to minimize overfilling. Tighten the reservoir only hand-tight.

Allow the oil to stabilize for one hour. Fill the oiler with Mobil SHC626 or equivalent, replace the oiler reservoir, and tighten it to allow the oiler to feed. Repeat as necessary until the oiler stops feeding (bubbles stop appearing). The oil level should be at or slightly above the center of the oiler sight glass (lower portion of oiler).

Series 3000, 4000, 5000, 6000

Oil Height Settings

The following instructions apply only to Power Mizer Series 3000, 4000, 5000 and 6000 blowers, which have adjustable oilers. Both bearings on these blowers must be checked for proper oil height settings before starting. Oiler level settings are preset at the factory, but an uneven foundation or shipping damage can disturb them.

CAUTION: Oil height settings are critical. The oil height in a bearing sump must be maintained within a narrow range to lubricate the bearing correctly. Too much or too little oil will lead to excessive heat generation, degrading the oil and shortening the bearing life.

First, be sure the sump and oiler are level. The oiler may be leveled or the oiler height adjusted by loosening the 8mm oiler bracket bolt. Leave some tension on the bolt to keep the oiler from moving too freely. With a small carpenter’s level, line up the oiler scribe lines with the sump sight glass and set the oil height as follows.

The inlet end bearing oil level scribe line should be set 1/16” below the bearing sump sight glass center. On the discharge end, however, the oil level scribe line should be even with the sight glass center.

Once stabilized, the oil level observed in the view port is the oil height in the oil sump. After initial operation, a level of approximately 1/8”-1/4” above the initial setting is normal when the blower is idle.

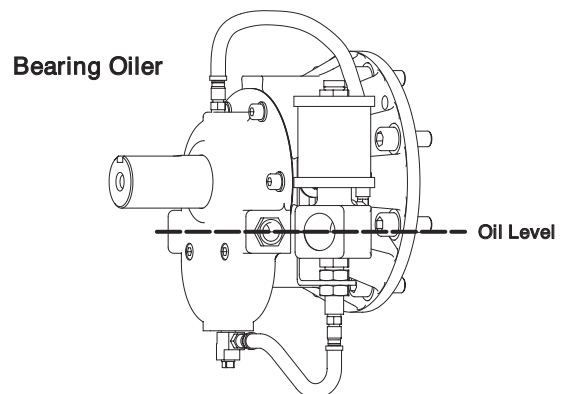

Filling Oilers

Replenish oil in the reservoir only after it drops below half full, which will reduce the number of refills. If the oiler needs frequent filling, this is not normal—look for an oil leak.

NOTE: Oilers ‘nuisance feed’ as the cap is screwed off and on, which can lead to an overfilled sump. Screw the oiler cap quickly to minimize overfilling. Tighten the cap only hand-tight.

The fill rate is slow on Series 3000, 4000, 5000, and 6000 machines. Let these machines sit, preferably overnight, until the oil is stabilized. If waiting is not possible, fill the sumps from the top vent—recognizing that this procedure can result in high oil levels as oil drains off internal components.

Series 7000, 8000

Oil Height Settings

Power Mizer Series 7000 and 8000 blowers have nonadjustable oilers hard-piped directly into the sump. There is no need to check oil height settings but make sure the sump and oiler are level.

Filling Oilers

Replenish oil in the reservoir only after it drops below half full, which will reduce the number of refills. If the oiler needs frequent filling, this is not normal—look for an oil leak.

Note: Oilers ‘nuisance feed’ as the reservoir is screwed off and on, which can lead to an overfilled sump. Screw the oiler reservoir quickly to minimize overfilling. Tighten the reservoir only hand-tight.

Allow the oil to stabilize for one hour. Fill the oiler with Mobil SHC626 or equivalent, replace the oiler screw reservoir, and tighten it to allow the oiler to feed. Repeat as necessary until the oiler stops feeding (bubbles stop appearing). The oil level should be at or slightly above the center of the oiler sight glass (lower portion of oiler).

Use only approved lubricants (see page 7).

CAUTION: Oilers must be filled and checked for proper oil level after each oil change.

CAUTION: Do not mix oils. Thoroughly drain the bearing sump and oiler before changing to a different oil.

Flexible Couplings

Couplings are lubricated at the factory with Texaco Code 1912 coupling grease and should be relubricated with identical or compatible grease every six months.

Two coupling lubrication ports are located 180° apart. Remove the setscrew lube plugs from both ports. Install a grease fitting in one port and rotate the coupling until the grease fitting is angled down at 45°. Pump lubricant in until it appears at the upper port. Remove the grease fitting and replace and tighten the lube plugs.

VIII. Maintenance

WARNING: DISCONNECT AND LOCK OUT ELECTRICAL POWER BEFORE PERFORMING MAINTENANCE.

Blower Bearing Removal and Replacement

NOTE: Refer to the appropriate view for the blower series involved. Some bearing system details may vary from those illustrated.

CAUTION: Note and record the orientation of the bearing housing and components, taking care to retain their position. Positioning may vary between grease and oil lubricated machines.

These illustrations (page 11) and instructions apply to the drive side of the blower. Bearings on the non-driven side are serviced the same, except the coupling guard, coupling, and motor need not be removed. Bearing housings are similar on both the inlet and discharge ends and serviced in a similar manner.

Series 1500

Bearing Removal Procedure

1. Remove the belt guard.
2. Release the tension in the belt drive and remove the belt.
3. Remove the belt pulley from the blower shaft.
4. Remove the bearing cap, locknut and lockwasher from the bearing housing.
5. After removal of the bearing housing screws, attach a flange type puller using the threaded holes for the bearing cap. Carefully remove the bearing housing and the bearing using the attached puller.
6. Remove the bearing from the bearing housing.

Bearing Replacement Procedure

1. Install components in reverse order of disassembly, starting with the installation of the bearing housing onto the blower.
2. Ensure that the bearing is completely seated on the shaft.
3. Lubricate according to the instructions on pages 8 and 9.

Checking and Adjusting Belt Tension

1. Remove the belt guard.
2. Use a tension checker to measure the belt deflection force in lbs. Refer to belt catalog tables for the correct deflection and tension values for your specific combination of belts and pulleys. Correct belt tension has been achieved when the measured deflection falls within the recommended range.
3. Use the adjustment screws on the motor slide base to move the motor closer to the blower if belt tension is too high, or further from the blower if tension is too low.
4. Replace the belt guard.

Series 2500, 3500

Bearing Removal Procedure

1. Remove coupling guard.
2. Split the coupling halves, recording the relative position of the motor and blower shafts (not the coupling shells).
3. Unbolt and move motor (if required).
4. Use puller to remove blower coupling half. Apply heat if necessary.
5. For oil-lubricated bearing, drain all oil by removing drain plug from the bottom of the bearing sump.
6. Remove bearing cap.
7. Remove shaft locknut, lockwasher, spacer, oil slinger, bearing retainer and sump if present.
8. Remove bearing housing bolts.
9. Using a two-arm puller and the two tapped puller holes (5/8" or 1/2") in the bearing housing, remove housing, bearing, bronze seal and grease slinger, if present, as a unit.
10. ‘Drift’ the bearing out of the housing. Note: Watch for a thrust washer that some bearings have behind the bearing.

Series 1500 (Grease)

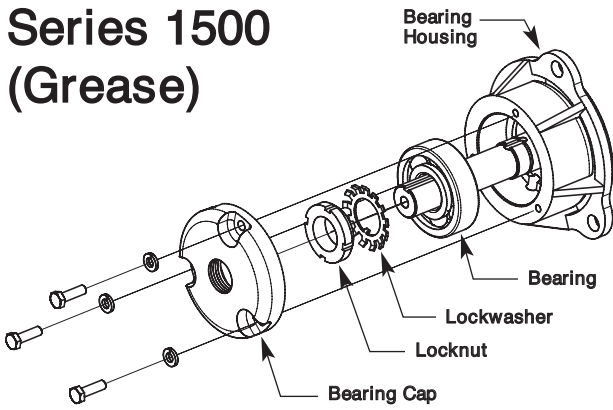

Series 2500, 3500 (Grease)

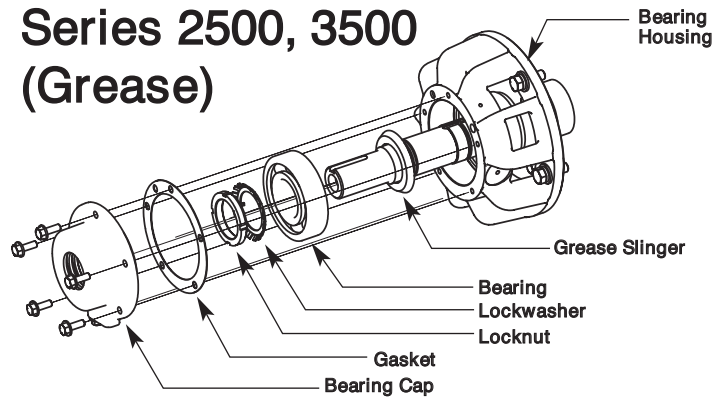

Series 2500, 3500 (Oil)

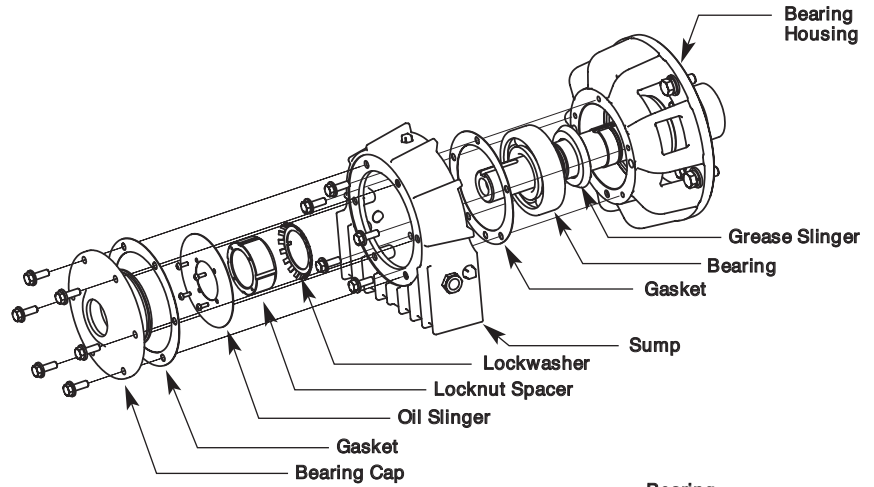

Series 3000, 4000, 5000, 6000 (Oil)

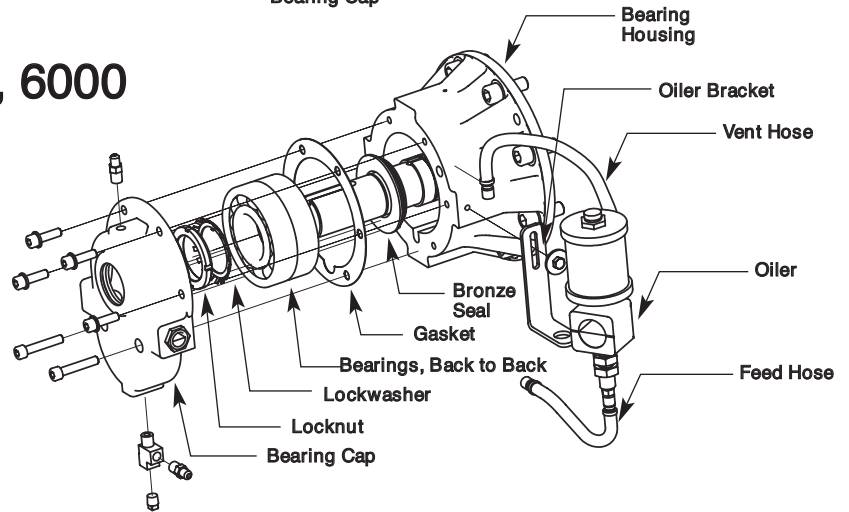

Series 7000, 8000 (Oil)

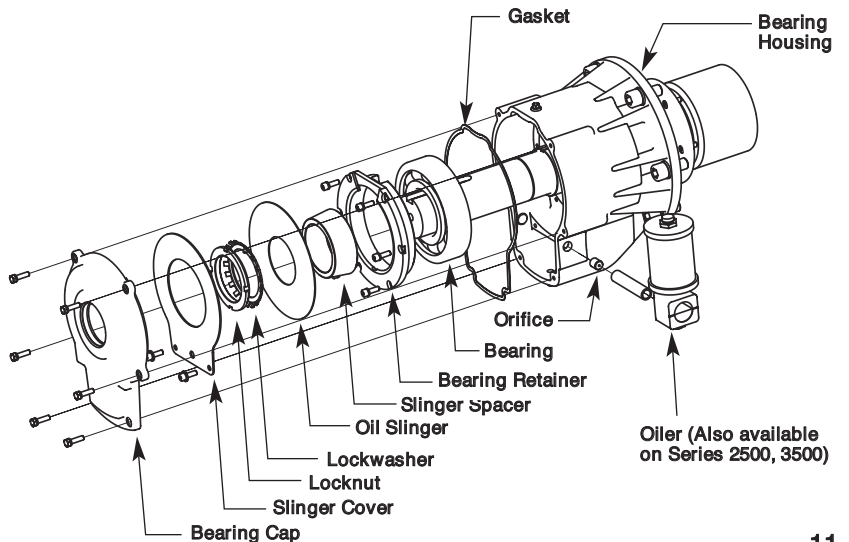

NOTE: Refer to the appropriate view for the blower series involved. Some bearing system details may vary from those illustrated.

NOTE: No shaft support is needed; the shaft will be supported by the labyrinth seals.

Bearing Replacement Procedure

CAUTION: Maintain extreme cleanliness to avoid bearing contamination and damage. Use new gaskets.

1. Install components in the reverse order of disassembly.
2. Press the bearing onto the shaft until seated against the shoulder. Pusher kits are available from Spencer.
NOTE: If present, oil slinger 'dimples' should face the bearing.
3. Lubricate according to instructions on pages 8 and 9.

Series 3000, 4000, 5000, 6000

Bearing Removal Procedure

1. Remove coupling guard.
2. Split the coupling halves, recording the relative position of the motor and blower shafts (not the coupling shells).
3. Unbolt and move motor.
4. Use puller to remove blower coupling half. Apply heat if necessary.
5. For oil-lubricated bearing, drain all oil by removing drain plug from the bottom of the bearing sump.
6. For oil-lubricated bearing, disconnect oiler tubing and oiler if necessary.
7. Remove bearing cap.
8. Remove shaft locknut and lockwasher.
9. Remove bearing housing bolts.
10. Using a two-arm puller and the two tapped puller holes (5/8") in the bearing housing, remove housing, bearing(s) and bronze seal, if present, as a unit.
11. 'Drift' the bearing(s) out of the housing.
NOTE: No shaft support is needed; the shaft will be supported by the labyrinth seals.

Bearing Replacement Procedure

CAUTION: Maintain extreme cleanliness to avoid bearing contamination and damage. Use new gaskets.

1. Install components in the reverse order of disassembly.
NOTE: If the assembly is equipped with a bronze rotation shaft seal, start the seal on the shaft, but do not seat.
2. Press the bearing(s) onto the shaft until seated against the shoulder. Pusher kits are available from Spencer.
NOTE: Double bearings must be installed back-to-back.
3. Lubricate according to instructions on page 9.

Series 7000, 8000

Bearing Removal Procedure

1. Remove coupling guard.
2. Split the coupling halves, recording the relative position of the motor and blower shafts (not the coupling shells).
3. Unbolt and move motor.
4. Use puller to remove blower coupling half. Apply heat if necessary.
5. Drain all oil by removing drain plug from the bottom of the bearing sump.
6. Remove bearing cap.

7. Remove slinger cover, shaft locknut, lockwasher, spacer, oil slinger, and bearing retainer.
8. Open a section of the ball cage on the bearing and cut the swarf out.
9. Using a blind housing puller kit (available from Spencer), insert the appropriate bearing adapter and rotate it 90 degrees to achieve a positive grip within the bearing race.
10. Prepare the opposite cage area in the same manner and insert the second adapter.
11. Connect both adapters to the main rod. Assemble beam and spindle.
12. Pull out bearing.

NOTE: No shaft support is needed; the shaft will be supported by the labyrinth seals.

Bearing Replacement Procedure

CAUTION: Maintain extreme cleanliness to avoid bearing contamination and damage. Use new gaskets.

1. Install components in the reverse order of disassembly.
2. Heat the bearing. Normally a bearing temperature of 80 to 90°C (144 to 162°F) above that of the shaft is sufficient for mounting.
CAUTION: Never heat a bearing to a temperature greater than 125°C (257°F), never heat a bearing using an open flame.
3. Press the bearing onto the shaft until seated against the shoulder. Pusher kits are available from Spencer.
NOTE: Oil slinger 'dimples' should face the bearing.
4. Lubricate according to instructions on page 7.

Labyrinth Seal Removal and Replacement

NOTE: Labyrinth seals are non-contacting and do not wear, but if a seal is damaged during bearing replacement, leakage will increase and the seal should be replaced.

1. Remove the bearing housing, following the appropriate bearing removal instructions in this manual.
2. Remove the heat fan if present. Disk-type heat fans are secured by two setscrews; bladed heat fans are clamped to the shaft.
3. Support the shaft and slide the seal clear. Gently lower the shaft.
4. Slide the new seal onto the shaft, raise and recenter the shaft, then seat the seal and fasten securely.

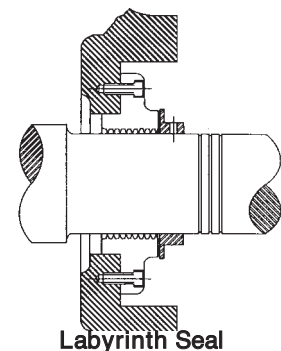

- CAUTION: Use care; the seal material is soft and easily damaged.**
5. Disk-type heat fan: Use a feeler gage to position the fan .050" from the seal face and tighten.
Bladed heat fan: Center the fan between the seal face and the bearing journal and tighten.
 6. Replace bearing(s) following the appropriate bearing replacement instructions in this manual.

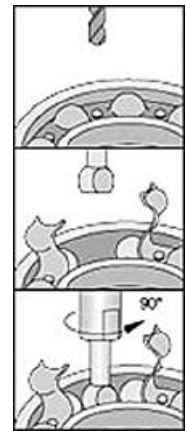

Field-Replaceable Parts

When ordering parts provide full information about your Spencer equipment, including the serial number and model number. Field-replaceable parts are restricted to the following:

- Drive end motor bearing
- Opposite drive end motor bearing
- Inlet bearings
- Discharge bearing
- Labyrinth seal or carbon ring
- Bearing cap gaskets

Equipment Service

Spencer provides prompt, courteous factory and field service for all Power Mizer machines. To determine the nature of the disorder and the best way to correct it, service personnel will be dispatched to your location. We typically request a Purchase Order prior to sending service personnel; however we will proceed on verbal orders in an emergency.

Once a full evaluation of the equipment has been performed by our service personnel, you will be advised if the service work is covered by the Spencer warranty. For out-of-warranty services, please note that we accept Visa and MasterCard charges as well as other forms of payment.

NOTE: Spencer products returned to the factory must be sent freight prepaid and accompanied by a Return Service Order

(RSO) issued by the Spencer Service Department after we receive your Purchase Order. Service costs will be quoted after inspection and the work will be performed upon written acceptance of the quotation.

Material Safety Data Sheets

Spencer is committed to ensuring the safety of its employees. If Spencer equipment has been exposed to potentially hazardous contaminants or if Spencer service personnel could be exposed to a potentially hazardous field environment, a Material Safety Data Sheet (MSDS) is required (a) prior to dispatching Spencer service personnel or (b) before receipt of any equipment for factory service. If special precautions are necessary to work on the equipment, contact the Spencer Service Manager.

Emergency Service

Emergency service calls after normal working hours can be routed through our voice mail system at 1-800-232-4321 and a Spencer service representative will return your call promptly.

Service and Operating Assistance

Spencer Representatives are always available to help customers achieve maximum equipment performance and reliability. Likewise, Spencer service personnel will provide on-site instruction during field service calls in the proper procedures to avoid a recurrence of the problem encountered.

IX. Troubleshooting Guide

PROBLEM	Possible Cause	Corrective Action
INSUFFICIENT AIR OR GAS THROUGH SYSTEM	Indication: low pressure/vacuum or volume as determined by gage measurement or process	
	• Incorrect rotation.	Change motor leads to correct rotation.
	• Air or gas lines too small, causing excessive friction loss.	Increase line sizes or install machine with higher output pressure.
	• Valves in line not fully open or check valve improperly installed.	Open valves or inspect check valve.
	• Inlet, discharge or piping system partially blocked.	Remove obstructions, clean filter.
	• High inlet temperature.	Position inlet in a cooler area.
	• Low inlet pressure.	Check inlet for obstructions or install machine with higher discharge pressure.
	• Machine not running at design speed.	Refer to motor manufacturer's instructions; check motor speed; check voltage connections.
	• Low gas density or specific gravity.	Check gas analysis and increase density or install machine designed for prevailing conditions.
	• Machine air passages clogged.	Consult Spencer Service Department.
• Impellers damaged by explosion, abrasion or vibration.	Consult Spencer Service Department.	
• Pressure or vacuum gage inaccurate.	Calibrate gage; always use a "U" tube manometer for checking pressure and/or vacuum.	
Indication: machine design capacity too small for the system		
• System requirements incorrectly calculated by customer.	Install larger volume or lower pressure machine to handle system requirements.	
• System leaks or too many openings.	Locate and repair leaks, reduce number of openings.	
Indication: measuring gas or air flow incorrectly		
• Flowmeters calibrated incorrectly.	Calibrate flowmeters; use proper orifice for meter (check with flowmeter manufacturer).	
• No means of measurement available.	Obtain and install flowmeter.	

IX. Troubleshooting Guide *(cont.)*

PROBLEM	Possible Cause	Corrective Action
MACHINE NOISY	Indication: machine malfunction – bearing whining or growling	
	<ul style="list-style-type: none"> • Bearing hot. • Bearing failure. • Bearing retainers worn. • Bearing turning on shaft, retaining nut loose. • Bearing turning in housing, housing worn. • Bearing replaced incorrectly (e.g., angled, cramped or reversed). 	<ul style="list-style-type: none"> Check lubricant, add or drain as necessary. Be sure oiler is functioning properly and screw cap is tightened properly. Replace bearing(s). Replace bearing(s). Tighten nut, check for damage. Replace housing and bearing. Follow installation directions carefully, check bearing, shaft and housing dimensions.
	Indication: machine malfunction – internal noise	
	<ul style="list-style-type: none"> • Impellers worn due to age or abrasion from dirty air or gas. • Machine in surge (see page 8). • Machine running rough, out of balance. • Coupling misaligned and/or out of grease. • Foreign matter in machine. • Impellers or shaft sleeve hitting. 	<ul style="list-style-type: none"> Correct abrasive conditions if present; consult Spencer Service Department regarding impeller replacement. Increase airflow. Consult Spencer Service Department. Check alignment, realign if necessary; check coupling for wear, replace if worn; relubricate as instructed. Consult Spencer Service Department regarding machine cleaning; install inlet filter to prevent clogging. Consult Spencer Service Department.
	Indication: motor malfunction	
	<ul style="list-style-type: none"> • Abnormal hum or whine. • Low voltage, motor not up to speed. • High voltage (causes noise and burnout). • Bearing noise (see previous instructions for blower bearings). • Loose part in motor. • Low frequency. 	<ul style="list-style-type: none"> Check motor manufacturer's instructions; check voltage supply and connections. Correct improper voltage. Correct improper voltage. Tighten, repair or replace (check with motor manufacturer). Correct improper frequency.
MOTOR HOT	(Check with surface thermometer; consult Spencer Service Department for assistance)	
	<ul style="list-style-type: none"> • Ambient temperature too high for insulation class. • Incorrect voltage. • Incorrect cycle. • Electrical short-circuit insulation failure. • Motor overloaded, too much air passing through blower. 	<ul style="list-style-type: none"> Cool motor or replace with motor having proper insulation. Change to correct voltage. Change to correct cycle. Repair or replace motor. Check for system leaks, throttle back butterfly valve, install larger motor.

IX. Troubleshooting Guide *(cont.)*

PROBLEM	Possible Cause	Corrective Action
VIBRATING MACHINE	Indication: mechanical fault	
	• Material buildup on impellers.	Consult Spencer Service Department for cleaning instructions, install inlet filter to prevent further buildup.
	• Shaft bent.	Consult Spencer Service Department.
	• Bearing failure.	Replace bearing(s).
	• Unbalanced replacement motor installed.	Balance motor.
	• Internal parts hitting.	Consult Spencer Service Department.
	• Impeller failure.	Consult Spencer Service Department.
	• Coupling misaligned.	Align coupling.
	• Inlet and/or discharge piping connected to machine without flexible connector, causing torque or stress on casing.	Install flexible connectors at inlet and discharge.
	• Machine bolted down, causing misalignment.	Remove bolts, use dowel pins or set in guide channels.
	• Bearing(s) cramped due to improper fit.	Check bearings, shaft and housing, correct bearing fit.
	• Piping not adequately supported.	Anchor piping properly beyond flexible connector.
	• Incorrect motor voltage, causing assembly to operate at improper speed.	Check voltage and wiring connections, correct voltage.
	• Solids passing through machine.	Consult Spencer Service Department regarding machine cleaning, install inlet filter to prevent further contamination.
	• Soft foot on motor or blower.	Follow alignment procedure on page 6.
• Machine in surge (see page 8).	Increase airflow.	
• Harmonic pulsation from gasoline engine driver.	Change engine speed to remove pulsation.	
• Machine not mounted on solid foundation.	Reinforce foundation.	
OIL LEAKS	Indication: Oil leaking from bearing housing	
	• System component tilted.	Make sure blower, oil sump and oiler are level.
	• High oil level causing air bubbles in oil and high oil temperatures.	Decrease oil level in reservoir.
	• Adjustable oiler at improper height setting (Series 3000, 4000, 5000, 6000 blowers).	Reset oil height—see page 9.
	• Air leak in oiler reservoir.	Check O-rings and gaskets, remove dirt and contamination. See Bench Testing Oilers, page 9.
	• Vent line missing or disconnected.	Install or reconnect vent line.
	• Oiler cap removed and replaced too slowly or too often, allowing 'nuisance feeding.'	Screw cap on and off quickly; refill only when oil level is down to 1/4 full.
	• Loose or overtightened oiler cap.	Hand-tighten cap, make sure O-ring is clean and in good condition.
• Loose fittings.	Tighten fittings.	



Spencer®

Products & Services

Industrially rated products offering effective solutions for air and gas moving problems:

- Multistage centrifugal blowers
- Single stage centrifugal blowers
- Gas boosters & hermetic gas boosters
- Regenerative blowers
- Modular central vacuum systems
- Mobile or stationary integrated vacuum systems
- Separators and dust collectors
- Custom-engineered products with special materials for extreme temperatures and pressures

Complementary accessories with single source convenience and compatibility:

- Standard and custom electrical control panels – UL, CUL Listed and C.E. Compliant available

- Dissolved oxygen control systems
- Comprehensive selection of tubing, fittings, vacuum hose, valves and tools
- Valves, gauges, couplings, shrink sleeves, vibration isolators and other system components

Comprehensive engineering and other customer support services:

- The industry's largest complement of technical specialists in air and gas moving technology
- Worldwide parts and service organization
- Application research and testing facility

Worldwide organization of sales representatives and distributors offering:

- Product selection, installation and operation assistance
- Comprehensive system design services
- Follow-up services and troubleshooting

For the name and telephone number of your local
Spencer Representative, call 1-800-232-4321
or email marketing@spencer-air.com



The

Spencer.

Turbine Company, 600 Day Hill Road, Windsor, CT 06095 USA

TEL 800-232-4321 ♦ 860-688-8361 ♦ FAX 860-688-0098 ♦ www.spencerturbine.com