

Spencer®

Technical Data Sheet

**Protect your vacuum system and your revenue
with an Island Knockout Separator,
specially designed for auto cleaning operations.**



Shown with optional vacuum accessories - hoses, tools and tool hangers.



Compact preseparator intercepts and collects bulky trash right beside the vehicle.

At fast-paced auto cleaning operations, hurried workers may vacuum up papers, food wrappers and liquids along with sand and other routine junk. It may be a potential setup for trouble. If the mixture clumps up in the vacuum lines, you've got to shut down the operation and snake the line. That involves costly router service charges and lost productivity.

Spencer's Island Knockout Separator (IKS) is your "advance guard" to protect the vacuum system from blockages, damage and resulting downtime. The IKS is a centrifugal preseparator equipped with two vacuum inlets and removable dirt can. It's typically installed on islands between auto cleaning lanes, connected to a vacuum tubing network and powered by a remote Spencer Industravac® vacuum system. Two operators can work at once, using 1-1/2" or 2" diameter hoses connected to the IKS vacuum inlets.

Features and Benefits

- Helps avoid system shutdowns and service calls due to plugged vacuum lines.
- Reduces downtime to help keep your operation running at top efficiency.
- Allows less frequent maintenance of the primary separator because heavy trash is intercepted early.
- Handles incidental liquid spills such as snow melt and shampoo suds.
- 2-1/4 cu. ft. metal dirt can is easily handled and emptied.
- Intercepts gravel and grit, reducing internal abrasion of the vacuum tubing.
- Removes most paper and plastic wrap that could "blind" the primary separator's filter bags and reduce suction.
- Promotes longer filter bag life; reduces bag damage that could allow unfiltered dirt into the vacuum producer.
- Each IKS can be isolated with an air gate valve for emptying without shutting down the entire vacuum system.
- Three standard models—two with inlet valves (1-1/2" or 2"), one without.
- Compact footprint allows easy fit on most islands or in tight spaces.

Spencer Island Knockout Separator

Dimensions

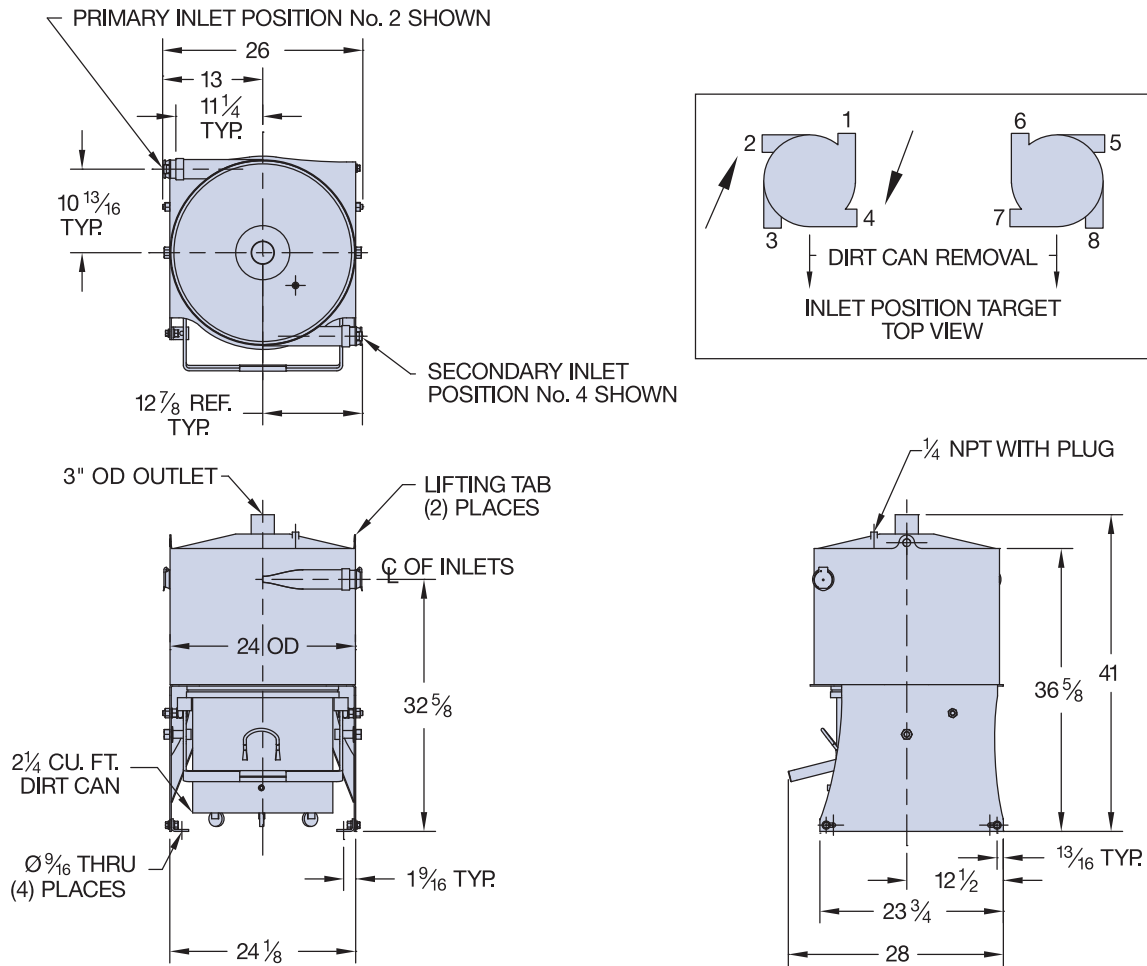

Part Number	Max. Vac. in. Hg	Hose Diameter	Primary Inlet Size	Secondary Inlet Size	Approx. Wt. lbs.
SEP90314	8	2"	2" FNPT w/ VLV90100	2" FNPT w/ VLV90100	120
SEP90313		1-1/2"	2" FNPT w/ VLV90083	2" FNPT w/ VLV90083	
SEP90312			2" FNPT	2" FNPT	

Notes:

- All dimensions are in inches. Multiply by 25.4 to obtain mm.
- Spencer reserves the right to make design improvements and/or change dimensions without notice.



The  **Spencer Turbine Company**, 600 Day Hill Road, Windsor, CT 06095-4706

TEL 800-232-4321 ♦ 860-688-8361 ♦ FAX 860-688-0098 ♦ www.spencerturbine.com

Blowers & Vacuum Systems with an Engineering Edge